

FP5 TRANS4M-R

Transforming
Europe's Rail Freight

D29.3

Installation and test plan for Gates in Spain

Project acronym:	FP5-TRANS4M-R
Starting date:	2022-12-21
Duration (in months):	54
Call (part) identifier:	HORIZON-ER-JU-2022-01 (Topic: HORIZON-ER-JU-2022-FA5-01)
Grant agreement no:	101102009
Due date of deliverable:	Month 36
Actual submission date:	2025-10-20
Responsible/Author:	Monica Pelegrin Preixens (ADIF)
Dissemination level:	PU - Public
Deliverable Type:	R - Document, report
Doc Version & Status:	V2.2 Submitted

Reviewed: (Yes)



"Funded by the European Union. Views and opinions expressed are however those of the author(s) only and do not necessarily reflect those of the European Union or the Europe's Rail Joint Undertaking. Neither the European Union nor the granting authority can be held responsible for them."

"The project is supported by the Europe's Rail Joint Undertaking and its members."

Document history		
<i>Revision</i>	<i>Date</i>	<i>Description</i>
1	2025-08-04	<i>Version 1.0 first version</i>
2	2025-08-05	<i>Version 2.0 sent for review</i>
3	2025-09-25	<i>Version 2.1 sent for review</i>
4	2025-10-09	<i>Version 2.2 sent to PM team</i>

Report contributors		
<i>Name</i>	<i>Beneficiary Short Name</i>	<i>Details of contribution</i>
Alejandro Mendizábal Roche	ADIF	Lead author, Editor, Chapter 1, 2, 3, 4, 5.1, 5.2, 6.1, 6.2.1, 9
Alexis Andrés Vidaurre Celis		
Mónica Pelegrín Preixens		
Rodrigo de la Iglesia Sánchez	INDRA	Chapter 6.2, 6.3, 6.4, 6.5, 6.6, 8.1
Francisco Parrilla Ayuso		
Markos Losada Gobantes	CEIT	Chapter 5.3, 7, 8.2
Iñigo Adin Marcos		
Alejandro Huergo Luz	RENFE	Technical reviewer

Reviewers		
<i>Name</i>	<i>Beneficiary Short Name</i>	<i>Details of contribution</i>
Luuk Spreeuwiers	Twente University	Official Review and Feedback
Florian Thiery	LTU	Official Review and Feedback

Disclaimer

The information in this document is provided “as is”, and no guarantee or warranty is given that the information is fit for any particular purpose. The content of this document reflects only the author’s view – the Joint Undertaking is not responsible for any use that may be made of the information it contains. The users use the information at their sole risk and liability.

The content of this report does not reflect the official opinion of the Europe’s Rail Joint Undertaking (EU-Rail JU). Responsibility for the information and views expressed in the report lies entirely with the author(s).

Table of Contents

1	Executive Summary	7
2	Abbreviations & Acronyms	8
3	Background	10
4	Objective/Aim.....	11
4.1	Task Description.....	11
5	Introduction to the demonstrator in Spain	12
5.1	Explanation on the Railway Checkpoints in Can Tunis	12
5.2	Introduction of the on-board sensors.....	12
5.3	Introduction of the data sharing aspect between both installations	13
6	Railway Checkpoints in Can Tunis	14
6.1	Can Tunis Terminal and the Railway Checkpoint locations.....	14
6.1.1	Location 1 - Llobregat	15
6.1.2	Location 2 - Morrot	16
6.2	Railway Checkpoint System Description	17
6.2.1	Operational Use Cases	18
6.2.2	System Functionalities.....	19
6.3	Railway Checkpoint system description by location	20
6.3.1	Location 1 – IRG_LL_G.....	21
6.3.2	Location 1 – IRG_LL_P	22
6.3.3	Location 2 – IRG_M_G	23
6.3.4	Location 2 – IRG_M_P.....	24
6.4	Installation of the Railway Checkpoints	25
6.4.1	Documentation required for the installation	25
6.4.2	Installation process.....	26
6.5	Detailed functioning of the Railway Checkpoint	27
6.5.1	Operational and functional requirements.....	27
6.5.2	Hardware	28
6.5.3	Software.....	36
6.6	Test plan	37
6.6.1	Hardware tests.....	38

6.6.2	Functional tests	40
6.6.3	Operation tests	42
7	On-board sensors.....	43
7.1	System Description	43
7.2	System operation.....	46
7.3	Functional features	47
7.4	Use case.....	48
7.4.1	Operational & Logistics	48
7.4.2	Condition monitoring	51
7.4.3	Cargo monitoring.....	51
7.5	Installation process.....	52
7.6	Test plan	54
7.6.1	Technological tests	54
7.6.2	Functional test.....	55
7.7	Preliminary tests	56
7.7.1	Installation issues.....	56
7.7.2	Results Obtained.....	58
8	Data sharing.....	62
8.1	On-track data.....	62
8.2	On-board data.....	65
9	Conclusions	67
10	References.....	68

Lists of Figures

Figure 6.1 Location of the Llobregat and Morrot sites inside Can Tunis	14
Figure 6.2 Location of Railway Checkpoints in Llobregat side	15
Figure 6.3 Location of Railway Checkpoints in Morrot side	16
Figure 6.4 INDRA's IRG (ERC implementation) System Architecture	19
Figure 6.5 Locations of the Checkpoint Gates	21
Figure 6.6 Checkpoint IRG_LL_G design at location 1	22
Figure 6.7 IRG_LL_P proposed installation at location 1	22
Figure 6.8 Checkpoint IRG_LL_P design at location 1	23
Figure 6.9 Checkpoint IRG_M_G design at location 2.....	24
Figure 6.10 Checkpoint IRG_M_P design at location 2	24
Figure 6.11 IRG_LL_G structural design.....	29
Figure 6.12 IRG_LL_P structure design	29
Figure 6.13 IRG_M_G structure design	30
Figure 6.14 IRG_M_P structure design.....	30
Figure 6.15 INDRA's Edge cabinet design	31
Figure 6.16 Detection cameras setup.....	32
Figure 6.17 Presence sensors setup.....	33
Figure 6.18 INDRA's Acquisition Camera design	34
Figure 6.19 Lateral cameras setup	34
Figure 6.20 Overhead cameras setup	35
Figure 6.21 Physical network setup for one gate	36
Figure 6.22 Global Safety lifecycle. Figure 2 of the standard IEC 61508.....	38
Figure 7.1 Demonstrator description for WP33	43
Figure 7.2 Network Topologies for the On-Board Digital System in Railway Logistics	44
Figure 7.3 CEIT's modular device for WOBUM, WOBUC, or WSEN operation.....	45
Figure 7.4 Device Operation According to its Role Within the System	47
Figure 7.5 Deployment of the On-board system.....	52
Figure 7.6 Primary suspension bogie frame and wheelset	53
Figure 7.7 Brake beam of the brake linkage.....	54
Figure 7.8 Central part of the bogie frame	54
Figure 7.9 Test carried out between Can Tunis and Morrot	56
Figure 7.10 On-board unit attached to the metal plate.....	57
Figure 7.11 Dashboard: Convoy Wagon Details (Identification & Composition)	58
Figure 7.12 Driver view and the Driver Desk	59
Figure 7.13 WOBUC and WSEN units within the wagon	59
Figure 7.14 Parameters related to the Cargo Monitoring	60
Figure 7.15 Parameters related to the Wagon Monitoring	60
Figure 7.16 Brake test recording for 3-axis acceleration	61
Figure 8.1 ERC data interfaces (reference to D29.1)	62

Lists of Tables

Table 4.1 Task descriptions and related output in the report	11
Table 7.1 List of parameters generated by the On-board system.....	48
Table 7.2 Placement of each On-board unit.....	53
Table 8.1 INDRA's composition message example (XML).....	63
Table 8.2 Train composition data	65
Table 8.3 Integrity & geolocation data	66
Table 8.4 Cargo Monitoring data	66
Table 8.5 Wagon monitoring table	66

1 Executive Summary

This document presents the installation and testing plan for the Railway Checkpoints in Spain, developed under *Task 29.2: Demonstration and Evaluation of the Installed Checkpoints*, within *WP29 Standardised European Checkpoints (ERC)*. WP29, part of the Flagship Project FP5-TRANS4M-R, aims to enhance cross-border rail freight operations through the development of *Intelligent Video Gates (IVGs)*, supporting the automation of Freight Train Transfer detection and inspections at borders or other operational stop points.

The ADIF/RENFE Spanish demonstrator seeks to validate the integration of IVG technology and on-board sensor systems in a high-traffic terminal environment. It focuses on assessing their interoperability with existing infrastructure and evaluating the effectiveness of data acquisition to support the monitoring and automation of railway operations.

A comprehensive overview of the ERC systems deployed by INDRA in Spain is provided, which includes an end-to-end solution for the automation of the operations addressed in the demonstrator, as defined in *D29.1: Technical Definition of the Standard IVG for Checkpoints and Related Demonstrators [1]*.

The document includes a description of the locations of the Railway Checkpoints at the Can Tunis terminal in Barcelona, the system architecture -use cases and functionalities-, description of the hardware, Information and Communication Technology (ICT) and software components, the installation plan, and the associated testing procedures.

The document also covers the on-board sensor system developed by CEIT, which forms an integral part of the Spanish demonstrator, in order to provide enhanced data for monitoring and analysis of railway operations. It includes a description of the system's architecture, the technical configuration, the data exchange mechanisms and the corresponding installation and testing plans.

The test plans described throughout this report are essential to ensure the quality and proper functioning of the demonstrator and will serve as the foundation for the activities to be carried out in the future deliverable *D29.6: Execution of Tests for Gates Installed in Spain*. The outcomes of this plan will contribute to defining best practices for future deployments and support the standardization of checkpoint technologies across European rail networks.

Keywords: European Railway Checkpoint (ERC), Spanish demonstrator, Intelligent Video Gate (IVG), Image analysis, Condition-Based Maintenance (CBM), Data exchange, On-board sensor system.

2 Abbreviations & Acronyms

Abbreviation / Acronym	Description
CBM	Condition-Based Maintenance
CDM	Conceptual Data Model
D	Deliverable
DL	Deep Learning
EMC	Electromagnetic Compatibility
ERC	European Railway Checkpoint
EU-RAIL MAWP	Europe's Rail Multi-Annual Work Programme
EVN	European Vehicle Number
FP	Flagship Project (within Europe's Rail)
GA	Grant Agreement
GCU	General Contract of Use for Wagons
GNSS	Global Navigation Satellite Systems
ICT	Information and Communication Technology
IEC	International Electrotechnical Commission
ILU	Intermodal Loading Unit
IR	Infrared
IRG	Intelligent Railway Gate
ISO	International Standardization Organization
IVG	Intelligent Video Gate
KP	Kilometric Point
LOBU	Loco On-Board Unit
LoRa	Long Range
LTE-M	Long Term Evolution for Machines
MAWP	Multi-Annual Work Programme
MQTT	Message Queuing Telemetry Transport
OCR	Optical Character Recognition
PPE	Personal Protective Equipment
RFIG	General Interest Railway Network
RGB	Red, Green & Blue
RTC	Real-Time Clock
TAF TSI	Telematics Applications for Freight – Technical Specification for Interoperability
TMS	Traffic Management System
TOS	Terminal Operating System
TRL	Technology Readiness Level
UPN	U Profile Normal
UWB	Ultra-Wideband
WOBU	Wagon On-Board Unit
WP	Work Package

WSEN	Wireless Sensor Elements
WSN	Wireless Sensor Network
XML	Extensible Markup Language

3 Background

This document constitutes the Deliverable D29.3: *Installation and test plan for Gates in Spain*, developed within the framework of the Flagship Project FP5-TRANS4M-R, as outlined in the EU-RAIL Multi-Annual Work Programme (MAWP).

The main objective of WP29, as described in the FP5-TRANS4M-R Grant Agreement (GA), is to develop and validate Railway Checkpoints that support the automation of freight train transfers at border crossings and other operational stop points. This objective is pursued through the deployment of *ERCs*, which integrate computer vision-based systems, integrating Deep Learning (DL) and Optical Character Recognition (OCR) technologies (Intelligent Video Gates), sensors, and other detection and identification technologies to digitalise and automate inspection processes.

Complementing the IVG deployment, the Spanish demonstrator also integrates an on-board sensor system to improve data acquisition for the continuous monitoring and analysis of railway operations.

The characteristics for the Railway Checkpoint and the on-board sensor system to be installed in Spain have previously been described in chapter 5.2 in Deliverable D29.1: *Technical definition of the standard IVG for checkpoints and related demonstrators*.

The expected Technology Readiness Levels (TRLs) for the key components of WP29 are as follows:

- Digitalisation and partial automation of manual processes using innovative and emerging technologies, based on a process analysis (TRL 7).
- Interoperable IT systems for data management and processing (TRL 7).
- Harmonized procedures and regulations.

4 Objective/Aim

This document has been prepared to provide the output of *Task 29.2: Demonstration and evaluation of the installed checkpoints*. The aim of the task is to demonstrate and evaluate the development of IVG checkpoints for cross border traffic, on main lines, at yards and terminals at suggested sites, based on the specifications in *Task 29.1: Technical definition of the standard IVG for checkpoints and related demonstrators*.

This task will result in an installation report and test execution for each of the considered countries (D29.2-29.7).

The present document focuses specifically on describing the installation of gates in Spain, including its functionality, technical specifications and the associated test plan to assess the fulfilment of its requirements.

Additionally, the installation and test plan of the on-board sensors that are included in the Spanish demonstrator is described.

4.1 Task Description

Task 29.2 started in project month 31 (January 2025), and the outputs of this task are included in this document.

The following Table 4.1 gives the direct match of the task definition from the proposal with the output and a link to the section where more details can be found.

Table 4.1 Task descriptions and related output in the report

	Task definition from GA (Task 29.2)	Output of deliverable
Task 29.2	Demonstrate and evaluate the development of IVG checkpoints based on the specifications in task 29.1 for cross border traffic, on main lines, at yards and terminals at suggested sites.	The present deliverable D29.3 focuses on describing the installation and test plan of IVGs at the Can Tunis freight terminal in Spain, with the objective of validating the solution for future deployments.

5 Introduction to the demonstrator in Spain

To fulfil the objectives of WP29 in Spain, Adif and INDRA are collaborating on the implementation of Railway Checkpoints at the Can Tunis freight terminal in Barcelona.

This installation is part of the European TRANS4M-R project, which aims to develop and integrate advanced technological solutions for monitoring and managing rail traffic. The system is aligned with the standards defined for a European Railway Checkpoint (ERC), as outlined in FP3 IAM4RAIL Project Deliverable *D25.1: Report on the basic functional and technical specifications for the realisation of the technical enablers of Seamless Freight, also including the final specification input for FP1* [2].

The Spanish demonstrator also incorporates an on-board sensor system developed by CEIT, aimed at improving data acquisition capabilities for the monitoring and analysis of railway operations.

5.1 Explanation on the Railway Checkpoints in Can Tunis

The Railway Checkpoints to be installed at the Can Tunis terminal constitute an advanced railway monitoring system designed to capture, process and analyse critical information about trains and their composition. These systems are composed of video gates equipped with sensors, high-resolution cameras and processing modules with artificial intelligence that allow the automatic identification of trains and wagons, as well as the detection of anomalies or dangerous goods and the gathering of operational data.

Each Railway Checkpoint will be strategically located on different tracks of the terminal, covering all entry and exit points for rolling stock, ensuring complete coverage of all traffic without interfering with the normal operation of the terminal.

5.2 Introduction of the on-board sensors

In addition to the Railway Checkpoints installed in the infrastructure, CEIT has developed an on-board system that allows continuous information to be obtained on the operations and events taking place on the trains where it is installed. This system consists of a set of sensors installed at strategic points on the wagon, designed to collect relevant data related to logistics, the cargo transported and the composition of the train.

The on-board integration of these sensors provides a more complete view of the status and behaviour of the rolling stock, allowing for improved traceability, optimised logistics operations and enhanced analysis of the data captured by the video gates.

5.3 Introduction of the data sharing aspect between both installations

With the objective of enhancing the information available for the monitoring and analysis of railway operations, the possibility of sharing data between the On-board sensors and the Railway Checkpoints installed on the infrastructure is envisaged. In both these cases with different sources (i.e. on-board sensors and IVGs), data will be initially captured and stored in cloud environments within the organizations' premises. Even though sharing such collected data externally among the partners offers numerous benefits (e.g. validation of calculated train compositions, merging information to derive additional values), it also involves several challenges at technical, legal and organisational levels.

A data space is regarded as a feasible approach to share data in cross-organizational use-cases and consequently, MotionRail-X data space from FP1-MOTION will be adopted in this demonstration to accomplish data transfers among the participants, i.e. CEIT, ADIF and INDRA. Once these organizations are registered in the data space, they will be provided with a data space Connector. A Connector is an essential software component that every organization needs to join and participate in a data space. It acts as a bridge, enabling organizations to publish data offers, negotiate contracts, and manage data transfers. By adhering the protocols defined by the IDSA, the Connector ensures smooth and compliant data exchange on a global scale. Supplementary middleware services will be implemented by each participant to provide data access and storage with the necessary authentication and authorization mechanisms. All these activities related to data sharing can be actively monitored through logs and dashboards. In this demonstration, such data exchanges will provide a more accurate correlation between the events detected on the track and the data generated by the rolling stock, improving traceability, incident detection, and the quality of data analysis.

6 Railway Checkpoints in Can Tunis

This chapter describes in detail the implementation of Railway Checkpoints at the Can Tunis railway terminal, within the framework of the Spanish demonstrator of the TRANS4M-R project.

6.1 Can Tunis Terminal and the Railway Checkpoint locations

Can Tunis is a key freight terminal in Barcelona, strategically connected to the national rail network (Red Ferroviaria de Interés General-RFIG), managed by ADIF, and directly linked to both the Port of Barcelona and the nearby Morrot terminal.

In Can Tunis, trains arriving from the national network (including cross border traffic) are distributed to the port as well as Morrot terminal. Similarly, trains originated in the port and Morrot are configured and sent to the national rail network from the terminal.

The Railway Checkpoints will be installed in two different locations at Can Tunis: to the west of the terminal, known as the *Llobregat* location, and to the east of the terminal, known as the *Morrot* Location. Both locations are situated at the ends of the terminal, as shown in Figure 6.1, being able to observe all inbound and outbound traffic. In this way, all rolling stock circulating through the terminal can be identified recording all entering and exiting times.



Figure 6.1 Location of the Llobregat and Morrot sites inside Can Tunis

It should be noted that the terminal is currently undergoing remodelling works that affect the layout of the access tracks, and therefore, the Railway Checkpoints have been designed to cover the final situation after the works have been completed.

6.1.1 Location 1 - Llobregat

The first location is in the west of the terminal (Llobregat), covering the entrance and exit to the RFIG, as well as an additional track connecting the Port of Barcelona, as illustrated in Figure 6.2. The installation of the Railway Checkpoints is envisaged to cover the traffic on these three tracks:

- **Double tunnel track:** This section corresponds to the entrance and exit of the RFIG, comprising two tracks. The checkpoint will be installed next to the entrance tunnel to the RFIG, at UTM coordinates X= 426151.983, Y= 4576970.544, corresponding to KP 707+950 (Llobregat Branch Tunnel) and KP 0+215.13 (Street 4 track).
- **Street 4 track:** This track provides access to and from the Port of Barcelona. The checkpoint is located at UTM coordinates X= 426145.785, Y= 4576956.529, corresponding to KP 0+205 (Street 4 track) and KP 717+938.221 (Llobregat Branch Tunnel).

It should be noted that the installation of the equipment on this gate will be conditional on the commissioning of the new track to be installed, as this track is currently involved in the ongoing civil works.

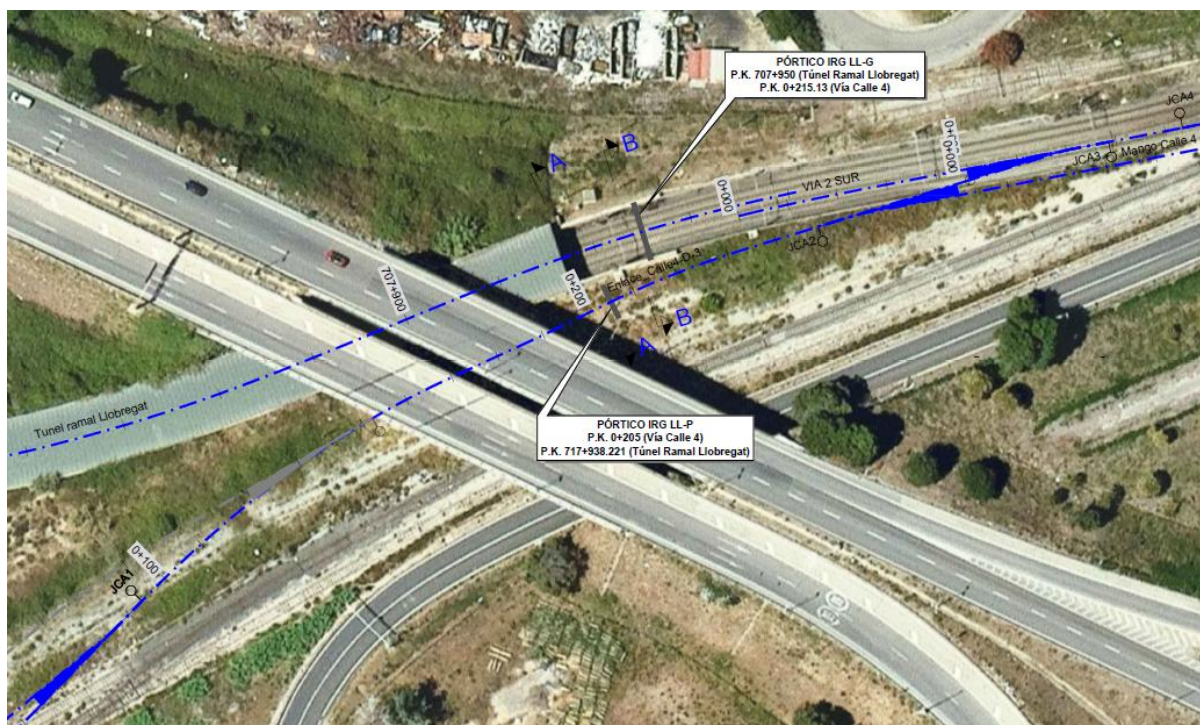

Figure 6.2 Location of Railway Checkpoints in Llobregat side

6.1.2 Location 2 - Morrot

The second location is situated on the eastern side of the Can Tunis terminal (Morrot), covering the entrance and exit of freight traffic to the Morrot terminal, as well as a track to access the port, as displayed in Figure 6.3.

The installation of two Railway Checkpoints is planned to monitor traffic across the following three existing tracks:

- **Morrot terminal access:** Two tracks corresponding to the entrance and exit to the Morrot terminal. The location is adjacent to the RFIG entrance tunnel, at UTM coordinates X= 428754.175, Y= 4578053.614.
- **Port ring access:** One track dedicated to the entrance and exit of freight traffic via the port ring. The installation point is located at UTM coordinates X= 428766.9, Y= 4578047.779.



Figure 6.3 Location of Railway Checkpoints in Morrot side

Therefore, there are a total of 6 tracks to be monitored using the Railway Checkpoints: three at Location 1 and three at Location 2. With the information collected by the Railway Checkpoints it is possible to accurately identify the rolling stock running through the Can Tunis terminal.

6.2 Railway Checkpoint System Description

The European Railway Checkpoint (ERC) is a modular system designed to enable and improve automation on inspection and monitoring operations, carried out in different points of the rail network. Its primary goal is to accelerate the digitalization of technical and administrative procedures at borders, terminals, marshalling yards and other critical nodes, where operational stops are required due to regulatory constraints. This way, ERC aims to optimise these operations, with the aim of reducing dwell times.

The ERC combines wayside monitoring technologies, data fusion mechanisms, and interfaces with external systems to generate a digital representation of the compositions. For the specific Spanish Use Case, demonstrated in Can Tunis terminal, the ERC system integrates sensing capabilities (light barrier industrial presence sensors), image analysis, and communication with external management systems to enhanced operational processes such as composition validation and dangerous goods identification in real time. The design of the ERC is aligned with the broader objective of improving interoperability, reducing border dwell times, and enabling seamless data exchange across Europe's rail corridors, as defined in D25.1 [2].

The concept of the ERC builds upon previous initiatives such as FR8Hub and FR8Rail, developed under the Shift2Rail programme. These projects demonstrated the potential of combining intelligent wayside technologies and data-driven processes to improve the efficiency of freight operations. The ERC, designed and developed under TRANS4M-R project, advances this vision by formalising the system's architecture, data interfaces, and functional components required to scale these capabilities across the European railway network.

Within this framework, the Intelligent Railway Gate (IRG) system, developed by INDRA, has been implemented as a technological realisation of the ERC. The IRG system encapsulates the core ERC capabilities through a modular product class approach, integrating the following functionalities:

- Train detection and speed estimation under different environment conditions and operational conditions (e.g. detection of trains operating on parallel tracks or running in opposite directions).
- High-resolution image acquisition from multiple views of the train.
- Multi-sensor integration, such as vision cameras and presence sensors.
- Compositions identification and validation.
- Dangerous goods identifiers—RID placards and UN numbers—, European Vehicle Number (EVN)—wagon codes—identification and Intermodal Loading Unit (ILU) identification through automated placard recognition.

- Irregularity and defect analysis aligned with standards such as General Contract of Use for Wagons (GCU) Appendix 9 [3] and Telematics Applications for Freight – Technical Specification for Interoperability (TAF TSI).
- Integration with Traffic Management Systems via standard interfaces, aligned with the Conceptual Data Model (CDM).

The IRG is designed to interact with Terminal Operating Systems (TOS) and Traffic Management Systems (TMS) platforms, enabling automated data synchronisation and real-time decision-making. It collects, processes, and shares data using the emerging European Conceptual Data Model (CDM), ensuring semantic compatibility and technical interoperability across systems and stakeholders.

6.2.1 Operational Use Cases

The ERC supports several operational use cases identified through the analysis of functional needs at various operational stop points along the European rail freight network. These operational stop points, defined in D25.1 [2] include:

- **Cross Border Operations**
- **Terminal Operations**
- **Shunting Yard Operations**
- **Workshop and Maintenance Integration**

Among these, **Cross Border Operations** and **Terminal Operations** are the primary focus of the Can Tunis demonstrator, where the ERC system is being deployed and validated in real operating conditions.

6.2.1.1 Use Case 1 – Cross Border Operations

Here, the objective of the ERC is to automate technical inspections and validate train compositions at international border points, reducing dwell times and improving regulatory compliance.

Description

At cross-border locations, the European Railway Checkpoint (ERC) system enables real-time detection and evaluation of critical train parameters before a train crosses a national boundary. This includes:

- Automated technical wagon inspections using image analysis, weighing-in-motion, and wheel impact load detectors to identify irregularities.
- Train composition verification, including locomotive and wagon identifiers, sequencing, and ILU (Intermodal Loading Unit) presence.
- Detection of hazardous goods, ensuring correct identification and labelling of dangerous substances.
- Integration of brake test results, via direct interface with on-board systems.

6.2.1.2 Use Case 2 – Terminal Operations

Here, the objective of the ERC is to automate entry and exit procedures for intermodal units, verify vehicle data, and improve safety and efficiency in terminal logistics.

Description

In terminal environments such as Can Tunis, the ERC supports:

- Automated gate operations, identifying wagons' European Vehicle number (EVN) and ILUs through sensors and cameras.
- Position tracking and timestamping, enabling real-time inventory updates and process optimisation.
- Integration with Terminal Operating Systems (TOS) for synchronised logging, validation, and reporting of all freight movements.

6.2.2 System Functionalities

The ERC implemented through the IRG system form INDRA delivers a modular and scalable design, including functionalities to support the automated inspection, validation, and monitoring of freight trains, as shown in Figure 6.4.

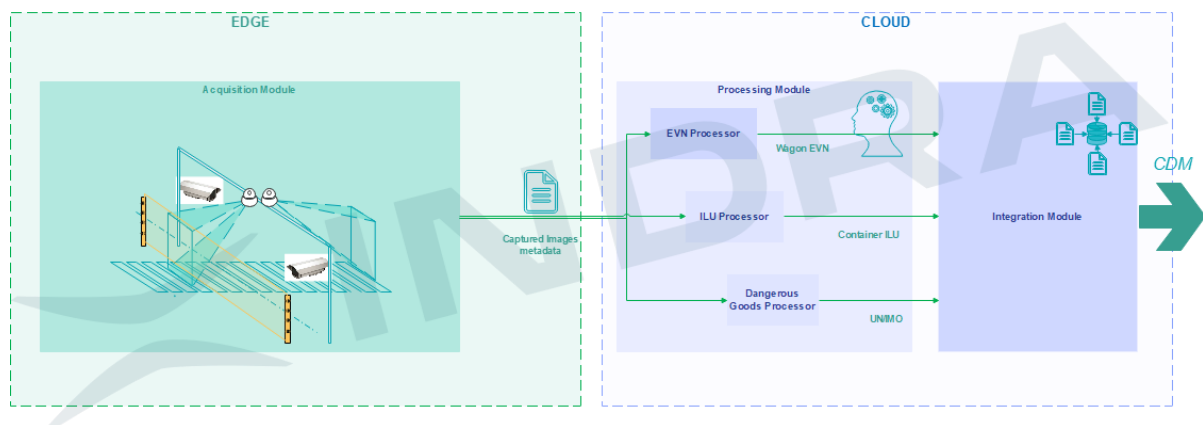

Figure 6.4 INDRA's IRG (ERC implementation) System Architecture

The core functionalities, implemented as modules, are summarised as follow:

6.2.2.1 Acquisition Module

The module is deployed on edge, having the following capabilities:

- The system detects and tracks trains at a given location by determining their presence, direction, and speed. This data is essential for acquiring high-resolution images, later processed by the Deep Learning models. The system combines various sensor sources (cameras and presence sensors) increasing its reliability.
- The system captures high-resolution images of passing rolling stock. The frame rate is dynamically adapted to train speed.

6.2.2.2 Processing Module

The processing module extracts structured information from images' classified data, such as:

- Vehicle EVN and ILU identifiers
- Hazardous materials codes (UN [4]/IMO [5] numbers)
- Possibility of detected technical defects (e.g., pantograph or wheel damage)

Each identified feature is packaged into structured messages and forwarded for data fusion.

6.2.2.3 Integration Module

Integration processes organise the data selecting the most accurate detections based on confidence levels. The results data -read codes of a rolling stock- is consolidated into a single, unified train composition message, ready for external use, and implementing the required standard interfaces through the adoption of CDM.

The structured output messages can be shared with external platforms such as TOS, TMS, or Maintenance Management Systems. CDM alignment ensures semantic interoperability.

6.3 Railway Checkpoint system description by location

The ERC system, developed by INDRA and based on its IRG product (the result of developments and implementations carried out in different Shift2Rail projects), will be installed and evaluated as part of Task 29.2, with tests under real conditions at the Can Tunis terminal, demonstrating its operational performance.

Four gates will be installed in the locations defined in Figure 6.5. Both locations are situated at the ends of the port, scanning the incoming and outgoing traffic of both the General Interest Railway Network (RFIG) and the port's own ring.

These structures will be equipped with high-resolution cameras and the necessary infrared presence sensors to detect, identify and characterise the rolling stock travelling at any given time through the two locations.



Figure 6.5 Locations of the Checkpoint Gates

The main objective of the systems is the identification and registration of all trains entering and leaving the Can Tunis terminal. At the Can Tunis terminal, trains arriving from the national rail network (including cross-border traffic), managed by ADIF, are distributed to different facilities. Similarly, trains departing to the national rail network (including cross-border traffic) are configured within the Can Tunis terminal. The functionalities of the gantries installed at both operational points make it possible to always record and characterise all the rolling stock running through the terminal, thus enabling the optimisation of operations within the terminal.

With the information recorded by these systems, it is possible to accurately determine the occupancy of the installation at any given moment. Furthermore, with the registration of the entry and exit time of each vehicle, it is possible to measure the time of stay, monitoring the occupancy and optimising the capacity of the port.

6.3.1 Location 1 - IRG_LL_G

The system is located on the two entry and exit lanes of the RFIG, on the tunnel structure. The system is designed and equipped to detect traffic on the two parallel lanes of the RFIG in both directions of traffic.

The gantry will be installed bolted on the existing concrete platform, as illustrated in Figure 6.6, and is composed of the following elements:

- 2 Detection cameras, located at the top of the gate, centred to cover both tracks in both directions, which are in charge of detecting a train, triggering the Image Acquisition system.
- 2 Train Detection Systems (TDS), each consisting of a barrier emitter and receiver (Light Curtain Sender and Light Curtain Receiver). The receiver sensor is connected to its own Edge Computing Unit which performs all logic processes for presence detection.

- 2 lateral analysis cameras, consisting of a housing containing high-resolution lenses. In addition, it incorporates a processing unit, responsible for image capture and the transmission of information on the local network and cloud. Each camera comes with an LED lighting system for each track (close and far to the camera) activated whenever the camera captures images.
- 2 zenithal analysis cameras, similar to the lateral ones.
- Power supply and communication system, integrated in the system's cabinet.

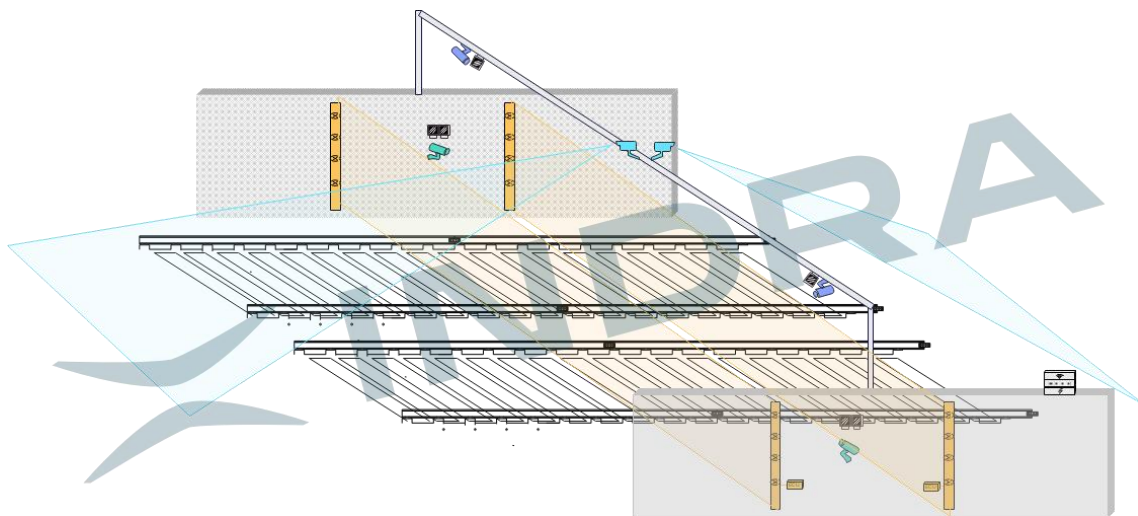

Figure 6.6 Checkpoint IRG_LL_G design at location 1

6.3.2 Location 1 - IRG_LL_P

The gate will be located to bridge a single track, the future mixed gauge track currently under construction. This (red) gate will be in charge of detecting traffic for a new track that will link with one of the main tracks (yellow), as shown in Figure 6.7.



Figure 6.7 IRG_LL_P proposed installation at location 1

The installation of equipment on this gantry will be subject to the operation of the new track to be installed. In the meantime, equipment will be installed on the south post,

equipped with video cameras and additional equipment for traffic identification on the two existing port entry and exit lanes at the Llobregat location, as shown in Figure 6.8.

This gantry is composed of the following elements:

- 2 Detection cameras.
- 1 lateral analysis Infrared (IR) camera, with its corresponding IR lights.
- Power supply and communication system, integrated in the system's cabinet.

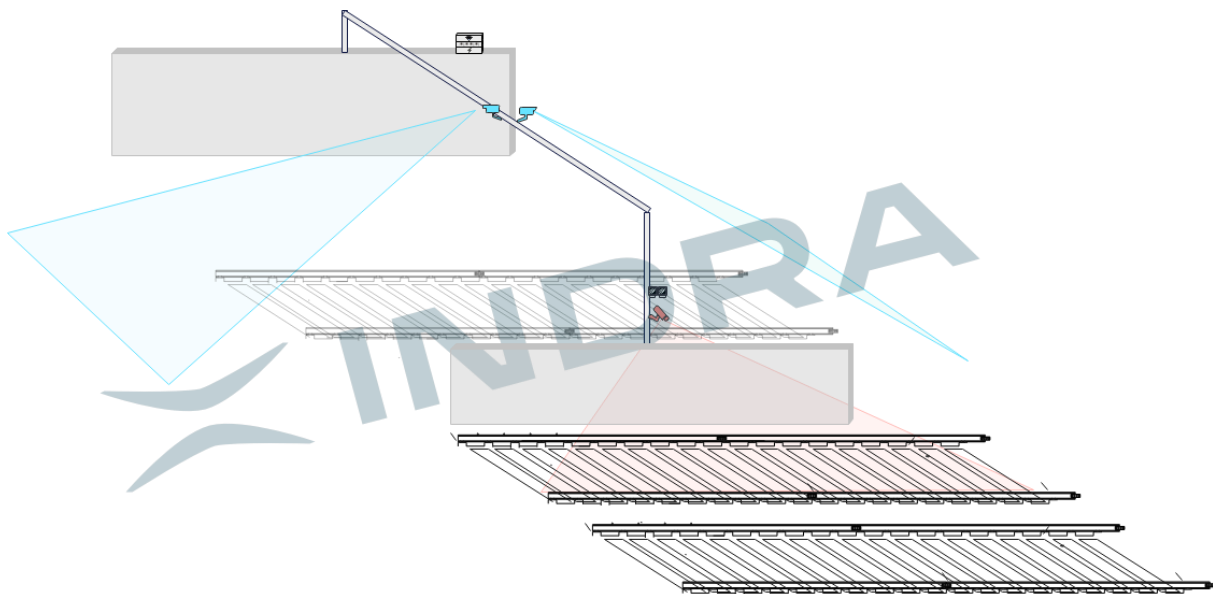

Figure 6.8 Checkpoint IRG_LL_P design at location 1

6.3.3 Location 2 – IRG_M_G

In this point the installation of a double track gantry is planned for the parallel entry and exit tracks of the RFIG at the Morrot location, as indicated in Figure 6.9. The installation of this IRG will require the laying of concrete foundations.

This gantry is composed of the following elements:

- 2 Detection cameras for both directions.
- 2 TDS connected to its own Edge Computing Unit which performs all logic processes.
- 2 lateral analysis and its corresponding LED lights.
- 2 zenithal analysis cameras, similar to the lateral ones, and its corresponding LED lights.
- Power supply and communication system, integrated in the system's cabinet.

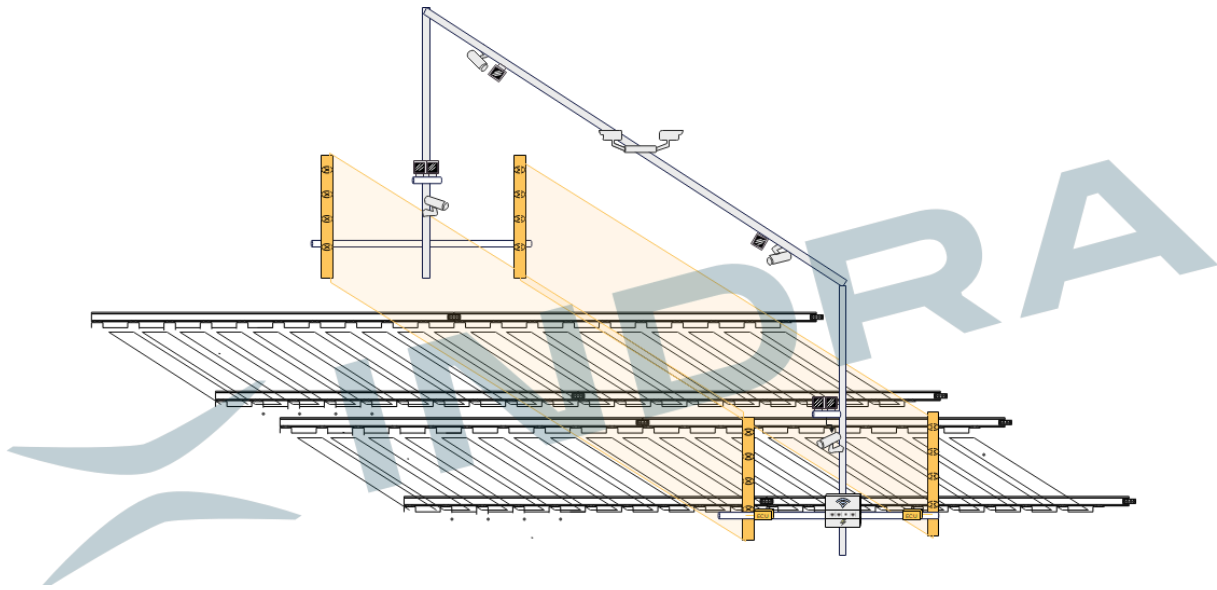

Figure 6.9 Checkpoint IRG_M_G design at location 2

6.3.4 Location 2 - IRG_M_P

This gantry will accommodate traffic on the port's entrance and exit roads at the Morrot location, for both directions of traffic, as presented in Figure 6.10.

This gantry is composed of the following elements:

- 2 Detection cameras for both directions
- 2 TDS connected to its own Edge Computing Unit which performs all logic processes.
- 2 IR lateral analysis and its corresponding IR lights.
- Power supply and communication system, integrated in the system's cabinet.

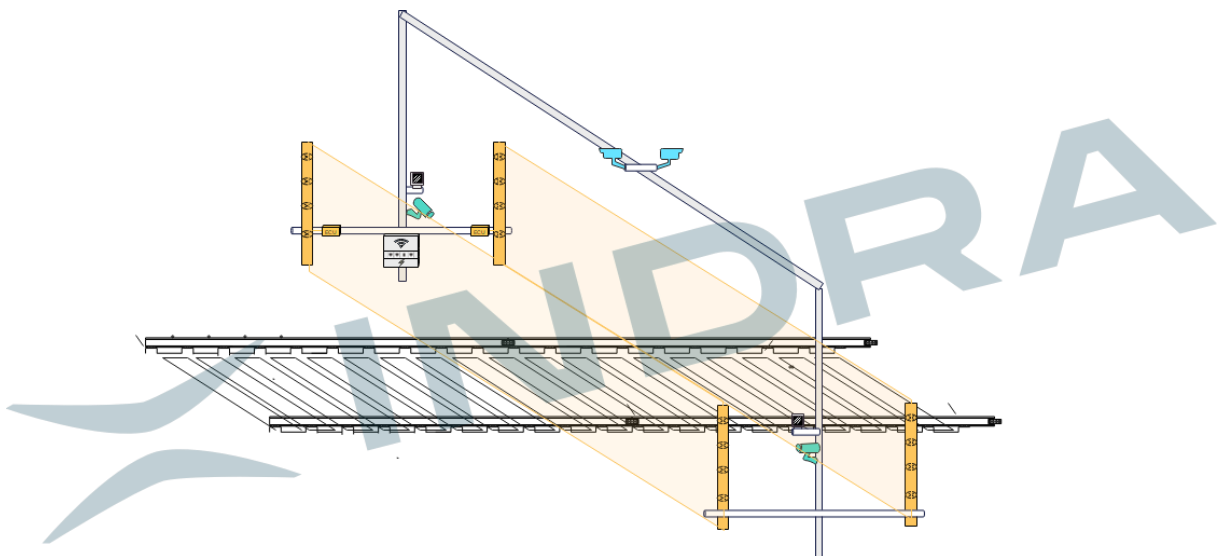

Figure 6.10 Checkpoint IRG_M_P design at location 2

6.4 Installation of the Railway Checkpoints

6.4.1 Documentation required for the installation

Railway Checkpoints installation at the Can Tunis terminal involves a series of alterations to the existing infrastructure and may affect the usual operation of the terminal. For this reason, a third-party impact document has been drawn up [6], which is a key part of the technical documentation required to carry out the installation. This document has already been forwarded to the relevant department. However, due to the pending approval, the physical installation of the gates has not yet been carried out.

This document describes in detail the proposed system, including the specific locations where the video gates will be installed, as well as the possible effects derived from their implementation. In addition, the mitigation measures planned to minimise the impact on the infrastructure and rail traffic are included.

The following is a summary of the main impacts identified, and the corresponding mitigation measures included in the document:

Impacts:

- **Affections on traffic:**
 - **During the installation phase:** Occasional track closures are foreseen, which will require coordination with ADIF for the allocation of maintenance windows.
 - **During operation:** No relevant interference is anticipated, as the system is designed to operate without affecting rolling stock and signalling systems.
 - **During the maintenance or calibration phase:** Calibration or maintenance tasks may require new maintenance windows and controlled track access.

- **Affections to the railway infrastructure:**
 - **Interference:** The system should not affect electrification, signalling, communications, or safety elements.
 - **During the installation phase:** The use of machinery will be limited to authorised access points, without invading the operational gauge. No dismantling of existing equipment is foreseen.
 - **During operation:** The installed equipment should not invade the operating gauge, does not emit electromagnetic signals vibrations, dynamic loads or electromagnetic emissions that interfere with infrastructure or signalling and traffic control systems.
 - **During the maintenance or calibration phase:** Interventions shall be carried out in maintenance windows agreed with ADIF.

- **Maintenance:** Preventive and corrective maintenance operations shall be conducted in accordance with established procedures, ensuring system interoperability and compliance with European technical requirements.

Mitigation measures:

- Planning of works to minimise operational impact.
- Track access only with track pilot, in accordance with regulations.
- Use of light machinery and low-impact auxiliary means.
- Application of occupational safety measures such as Personal Protective Equipment (PPE), hygiene facilities or preventive supervision.
- Continuous coordination for validation of procedures and supervision of activities.
- Once the installation is completed, the system does not require track interventions, nor does it affect structural or signalling subsystems.

6.4.2 Installation process

The installation of the systems in the locations described in section 6.1 is divided into several tasks. The planning and execution of these tasks has been carried out by INDRA, some of them requiring the intervention of ADIF for the approval of relevant permits or the provision of infrastructure facilities.

Preliminary Activities and Design Phase

The project started with an initial site visit to Can Tunis in December 2023, to assess the location. Following this, the preliminary design phase began, resulting in the first conceptual documentation. Administrative coordination with ADIF was addressed through dedicated efforts, including meetings and documentation presentations.

Detailed Design and Planning

Due to scope changes and infrastructure constraints transmitted by ADIF, a second site visit took place in February 2025, followed by the submission of Affections documentation in April 2025. The detailed design phase started in February 2025, and continues through June 2025, representing the technical foundation of the system.

In parallel, the equipment procurement and preparation phase spans from December 2024 to September 2025. Equipment reception at the factory is scheduled for September 1, 2025. Additionally, Affections document approval is expected between June and August 2025, which approves the on-site installation works.

Site Preparation and Civil Works

The first survey visit, covering topographic measurements, is planned for September 2025. This is followed by foundation work for the Morrot and Llobregat gates. A second

survey visit to define gate positioning is expected to take place between September and October 2025. Structural components will be delivered and stored on-site from this point.

Installation of Structures and Equipment

The installation of portal structures will be conducted once structures are installed, including individual tasks for each IRG:

- Llobregat Large Gate (LL_G): Structure installation and cabinet connections.
- Llobregat Small Gate (LL_P): Structure installation and cabinet connections.
- Morrot Large Gate (M_G): Structure installation and cabinet connections.
- Morrot Small Gate (M_P): Structure installation and cabinet connections.

System Integration and Testing

Calibration and fine-tuning of systems are scheduled for November 2025, followed by the creation of As-Built documentation. The test plan of this installation is examined in this document.

Testing and Final Validation

The system will undergo initial tests for ERJU deliverables from November 24 to December 2025. These will be followed by complementary extended testing from December 2025 to May 18, 2026, ensuring full functionality and compliance before final approval.

6.5 Detailed functioning of the Railway Checkpoint

6.5.1 Operational and functional requirements

The functional and operational requirements defined for Railway Checkpoints, in accordance with the standards and objectives of the ERC, are detailed below. These requirements have been defined with the objective of guaranteeing the correct operation of the system by ensuring its ability to capture, process and analyse relevant data.

Operational requirements:

- **Safety and Compliance:** The system must comply with applicable safety regulations for railway installations, including Electromagnetic Compatibility (EMC), fire protection, and physical clearance requirements.
- **Operating Environment:** The system must function reliably in outdoor terminal conditions, exposed to variable weather, temperature fluctuations, dust, and vibrations.
- **Scalability and Modularity:** The system architecture must allow for future expansion (e.g., additional sensors) without requiring major redesigns or infrastructure changes.
- **Maintenance and Accessibility:** Components must be accessible for routine maintenance without disrupting terminal operations. Preventive maintenance

intervals shall be defined based on manufacturer specifications and operational load.

- **Integration constraints:** The system must interface seamlessly with existing yard management and traffic control systems.

Functional requirements:

- **Location coverage:** The system must cover all locations defined in previous sections.
- **For detection cameras:**
 - Detect the presence of incoming rolling stock.
 - Identify the direction of movement.
 - Determine the specific track the train is on.
- **For detection sensors:**
 - Monitor track occupancy.
 - Ensure accurate detection of trains on specific tracks
- **For acquisition cameras:**
 - Capture images of rolling stock moving along the track. All images captured for a composition must cover the entire area of the composition.
 - Save all the captured images for further processing.

6.5.2 Hardware

Gates

The gates part of the Can Tunis deployment has been designed to monitor freight traffic on different track sections, ensuring compliance with electrification clearances (NAE 107 [7]) and optimal visibility image capture.

- **IRG_LL_G structure**

IRG_LL_G spans two RFIG tracks (12 m), installed on the existing tunnel platform. Equipment is mounted both on the gantry and on lateral platforms, as illustrated in Figure 6.11. The structure includes UPN columns, attached to the existing structures.

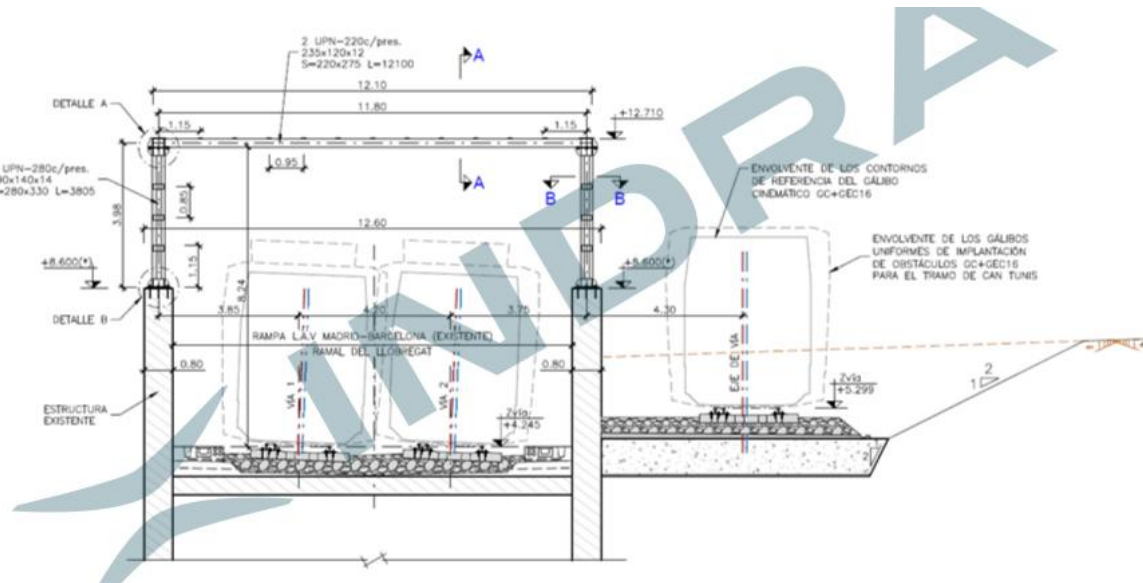

Figure 6.11 IRG_LL_G structural design

- **IRG_LL_P structure**

IRG_LL_P spans a future third track (7.60 m) and is anchored to existing concrete walls within the Llobregat area. It is designed for electrified operation, with UPN columns attached to the existing structures, as shown in Figure 6.12.

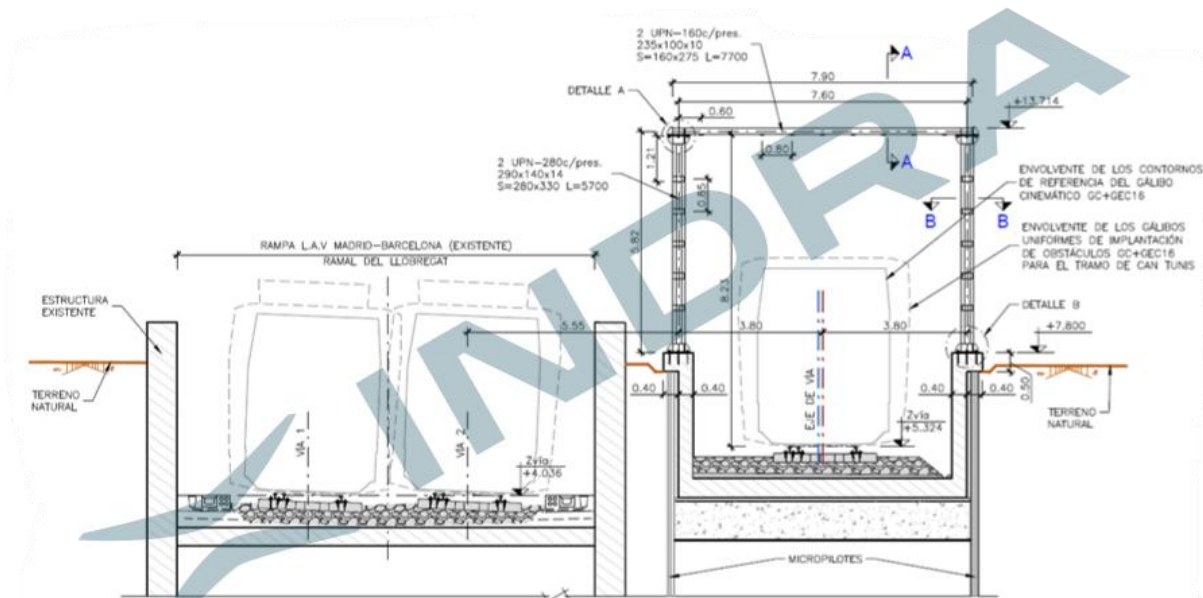

Figure 6.12 IRG_LL_P structure design

- **IRG_M_G structure**

IRG_M_G spans two tracks (13 m) and is supported on newly built foundations. Positioned to avoid interference with catenary and signalling, it uses UPN columns mounted over concrete foundations, as shown in Figure 6.13.

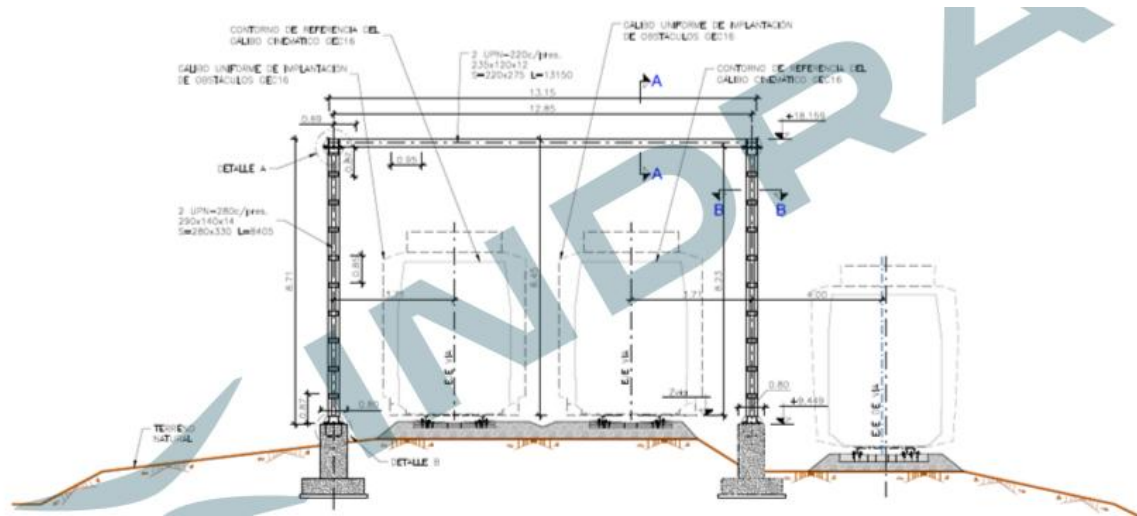

Figure 6.13 IRG_M_G structure design

- **IRG_M_P structure**

IRG_M_P spans one track (7.40 m) within the port terminal. Uses UPN mounted over concrete foundations as displayed in Figure 6.14.

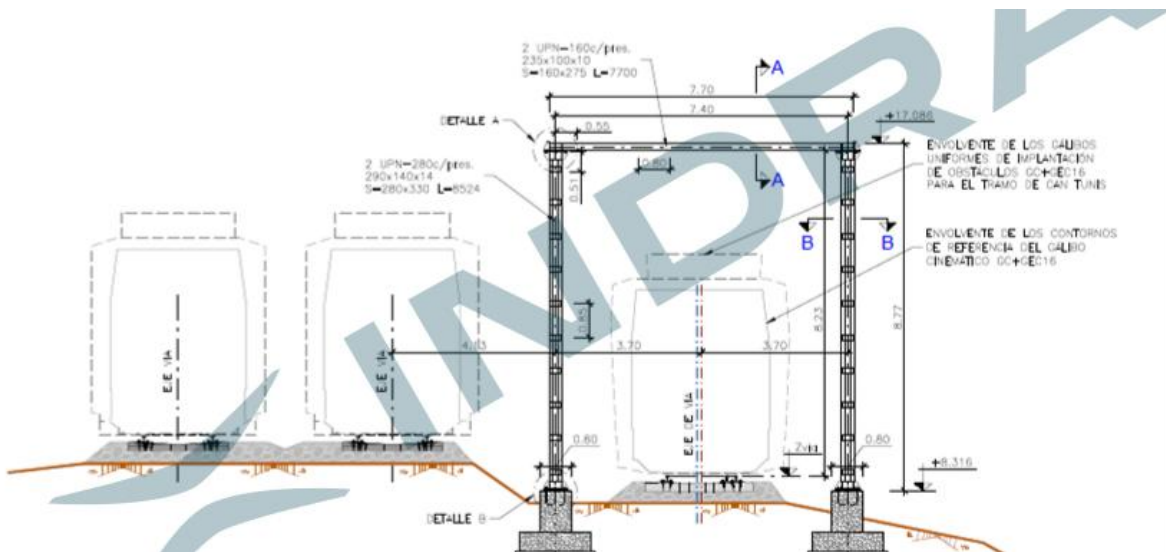

Figure 6.14 IRG_M_P structure design

INDRA's Edge Cabinet

For the power supply and network connection of the equipment installed at the Edge. As can be observed in Figure 6.15, INDRA has designed a cabinet tailored to the installation requirements.

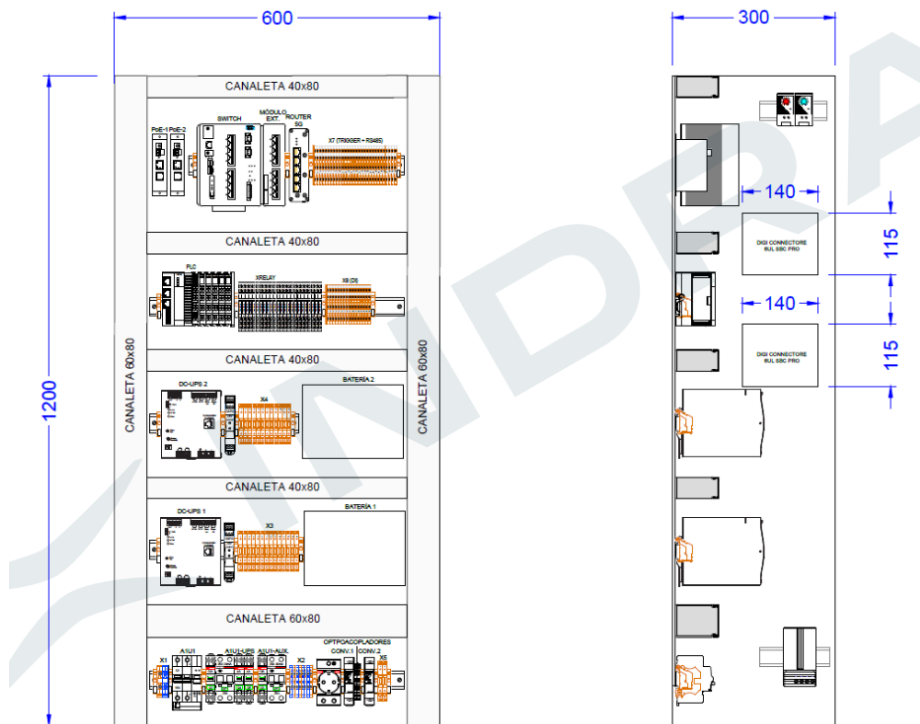

Figure 6.15 INDRA's Edge cabinet design

Detection Cameras

The detection cameras are part of the train detection subsystem of the INDRA IRG system. The detection cameras shall be installed centred on the gate to allow a clear and accurate view of approaching trains in both directions of traffic, as illustrated in Figure 6.16. These cameras shall identify the presence of a train, the running track in case there are several for the same gantry, the direction and speed, so that the acquisition of images to be analysed is accurate and robust.

The installation of the system, designed by INDRA, allows flexibility and adaptability to the different environments of the demonstrator.

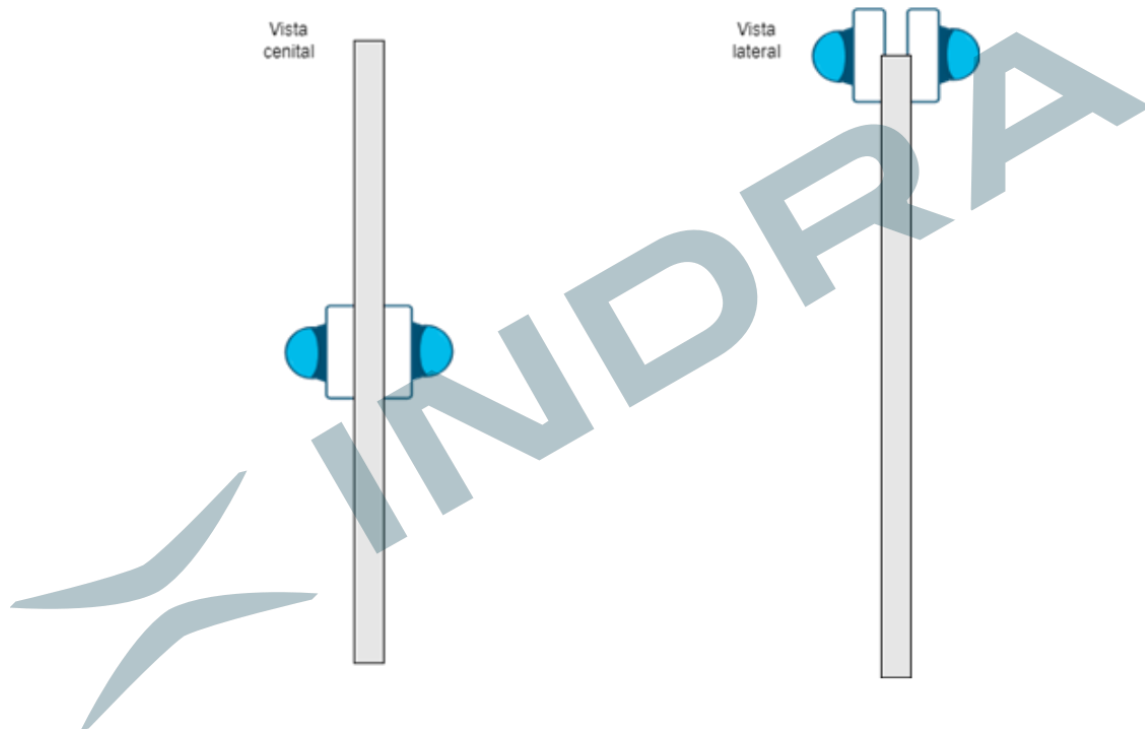

Figure 6.16 Detection cameras setup

Presence sensors

INDRA's train detection sub-system is robust with presence sensors. These sensors, installed on both sides of the gantry, as displayed in Figure 6.17, confirm the presence of rolling stock and serve as Ground Truth for the general detection system.

Each presence sensor consists of an infrared light emitter and a receiver device. These devices must be perfectly aligned to avoid false detections.

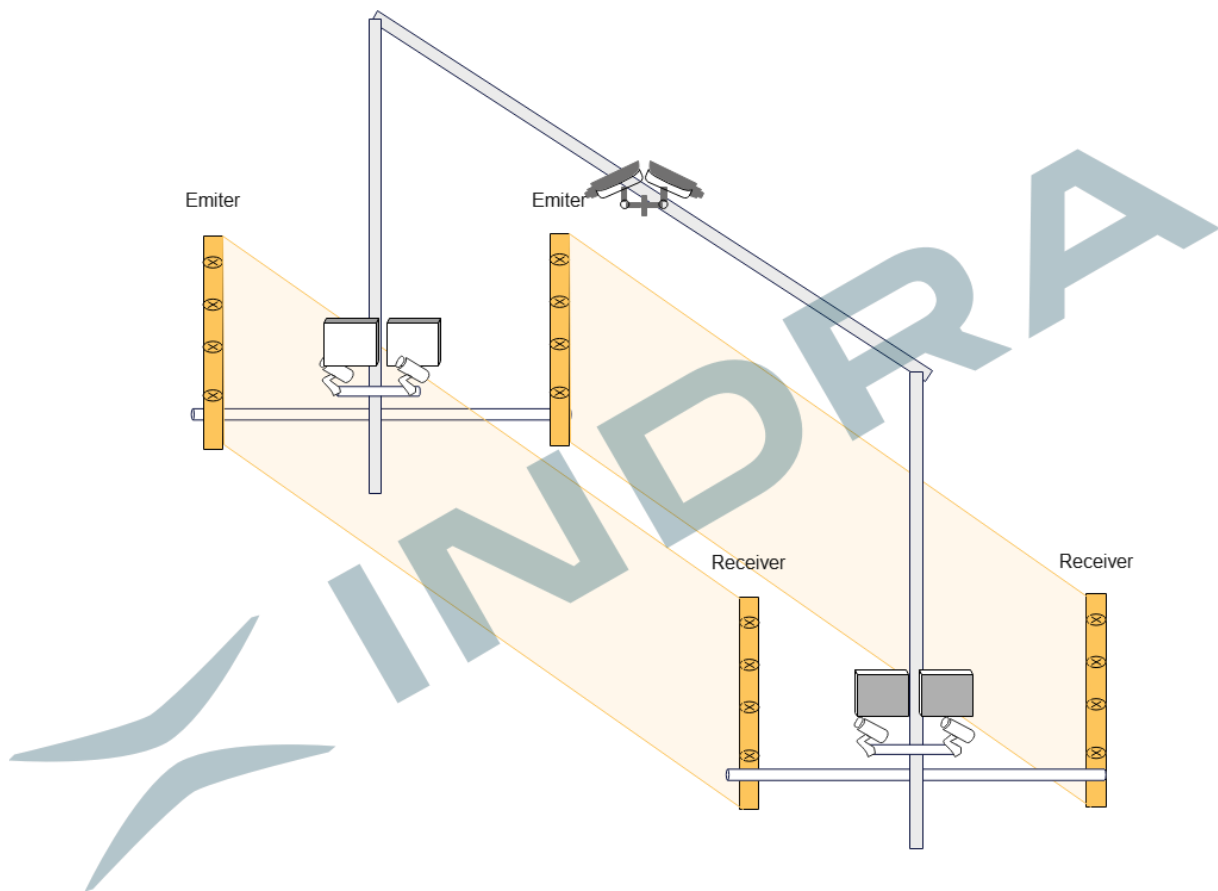

Figure 6.17 Presence sensors setup

Acquisition subsystem

The Acquisition subsystem consists of both acquisition cameras and illuminations, as shown in Figure 6.18, in charge of capturing high-resolution images of rolling stocks to be analysed. Depending on the location and its requirements, the acquisition system may consist of infrared (IR) or white light (RGB) equipment.

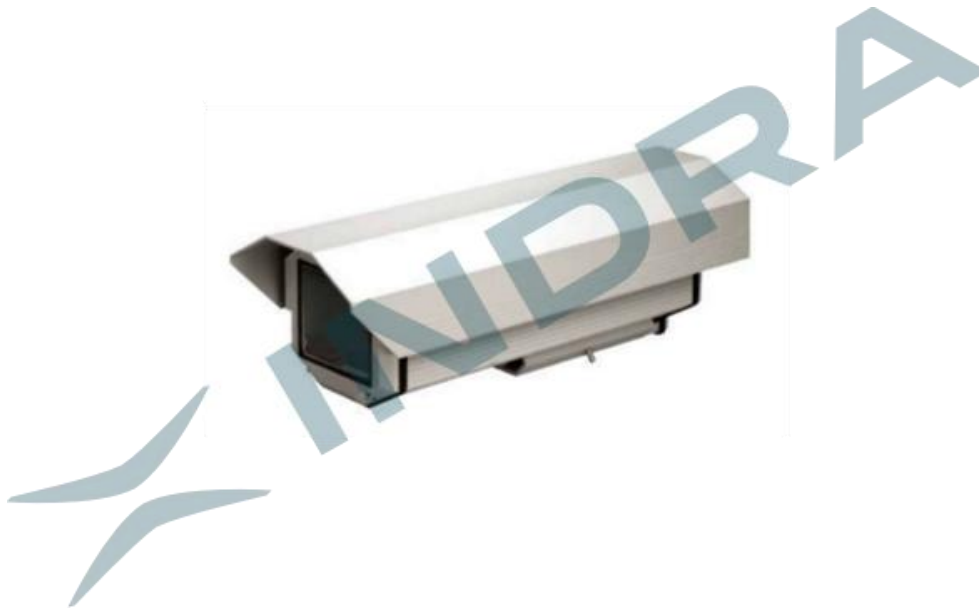

Figure 6.18 INDRA's Acquisition Camera design

The subsystem is composed of side acquisition cameras, which capture images from the sides of the wagons to recognise wagon and container identification codes and markings, as illustrated in Figure 6.19.

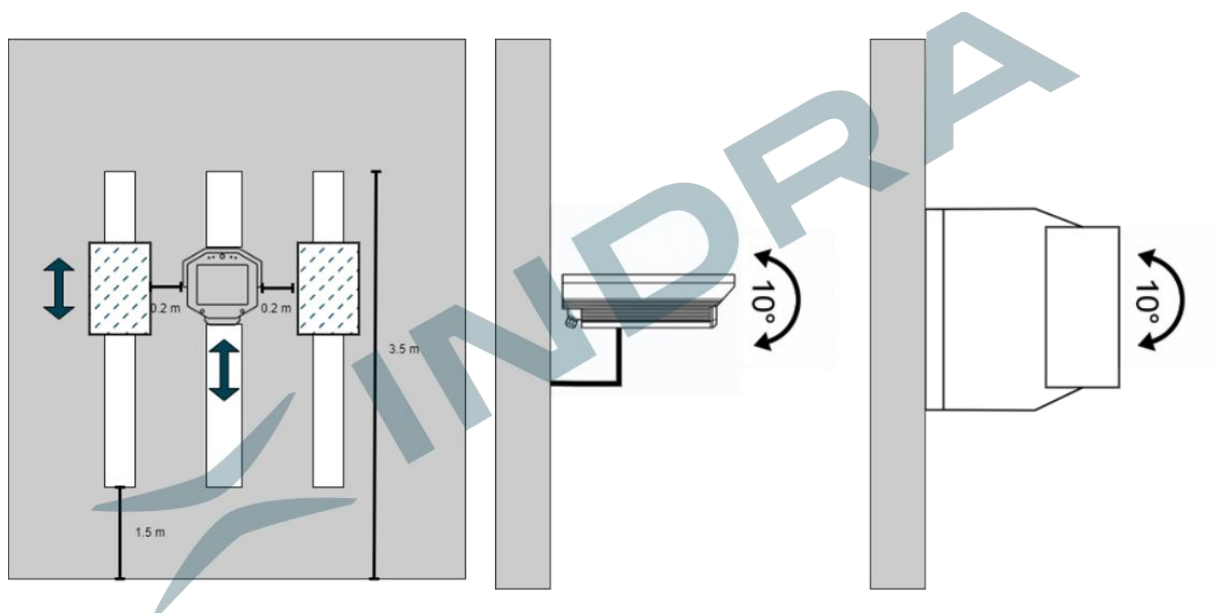

Figure 6.19 Lateral cameras setup

In addition, as depicted in Figure 6.20, overhead cameras are installed above the trains, capturing images from the top of the trains.

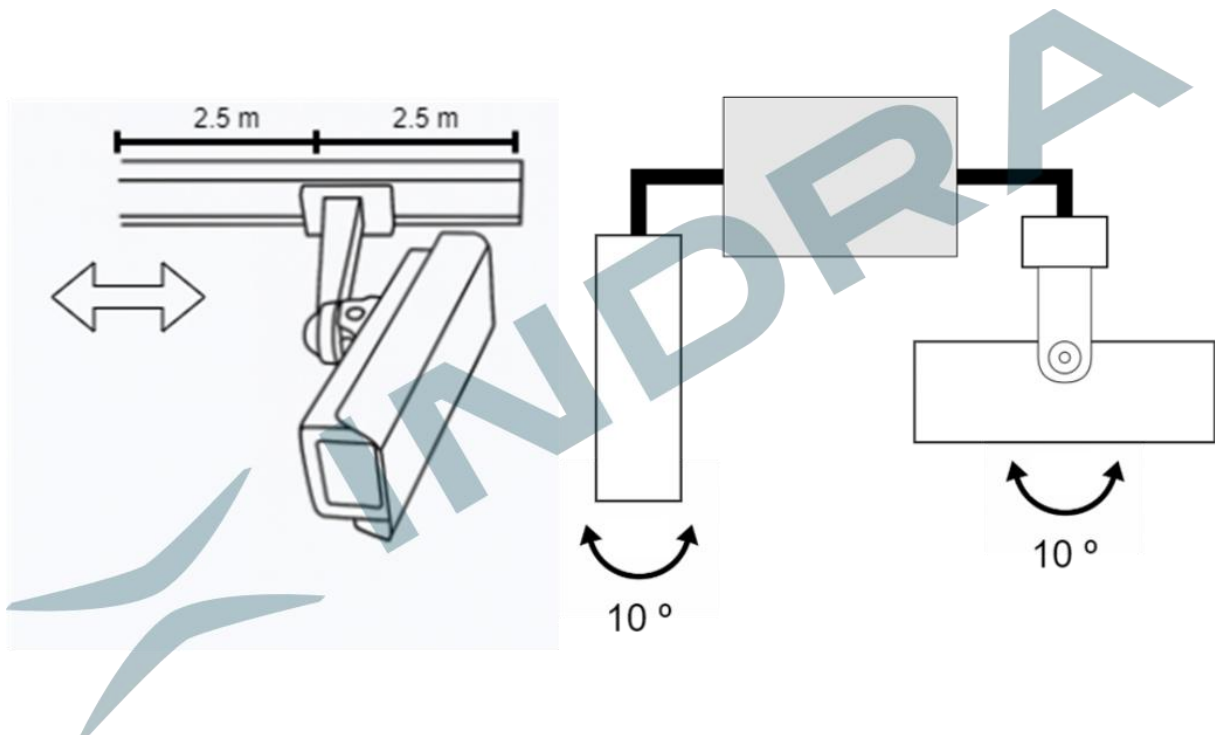

Figure 6.20 Overhead cameras setup

Communications

All subsystems deployed in the IRG system are modular and asynchronous. These modules are executed in both EDGE and CLOUD environments, maintaining a constant transfer and recording of information. This communication is established through both Ethernet and 4/5G network interfaces, as can be observed in Figure 6.21.

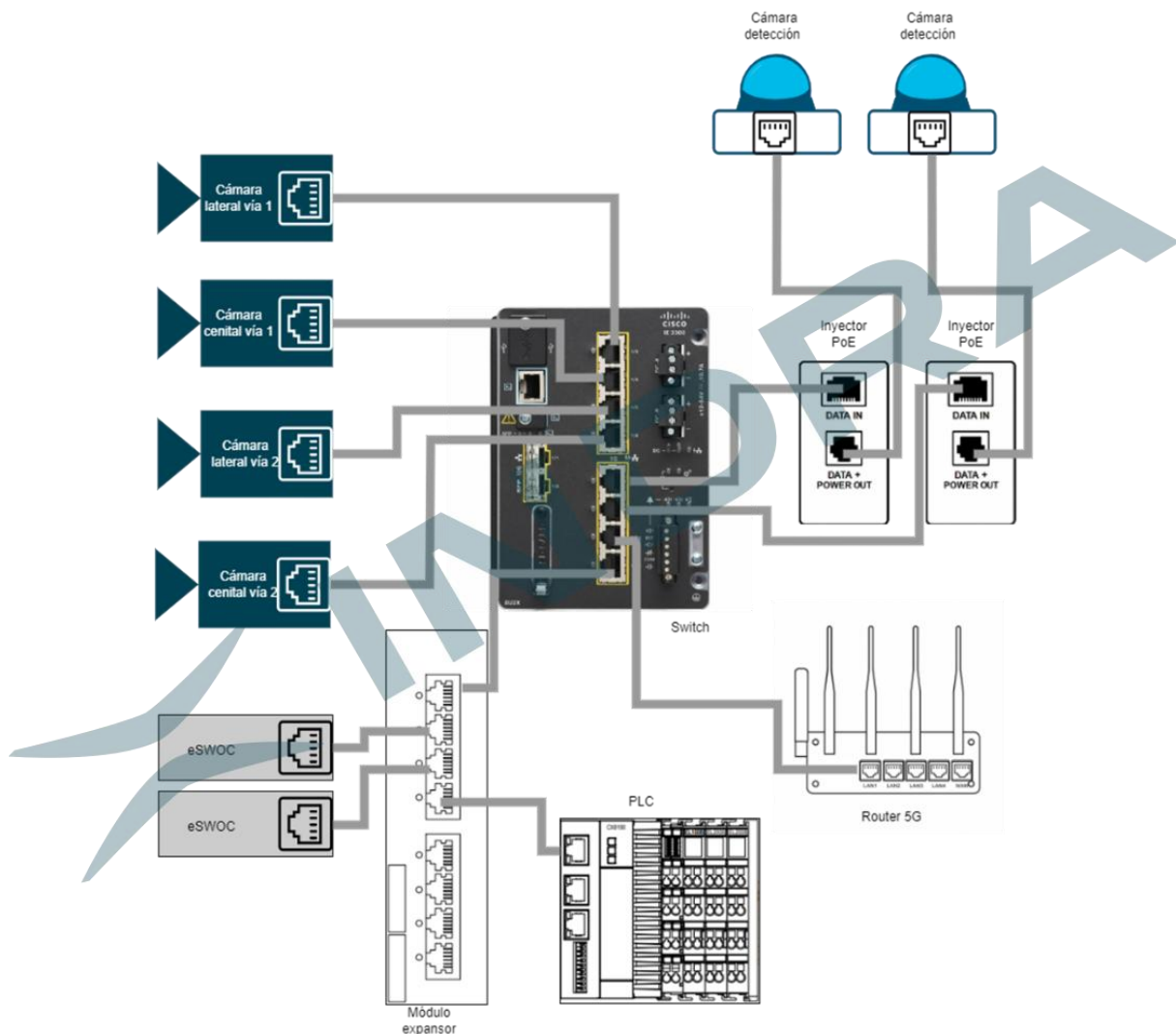

Figure 6.21 Physical network setup for one gate

6.5.3 Software

INDRA's IRG system, installed in the different locations of Can Tunis, is based on a modular and distributed design. The modules, corresponding to each subsystem, can be deployed in both EDGE and CLOUD environments, thus defining an architecture adaptable to the specific conditions and requirements of the installation.

The system comprises multiple modular software components, each responsible for a specific function in the rail inspection and data management workflow. Key modules include:

Train Detection: Detects the presence, speed, and direction of trains using inputs like video and sensor signals. Each detection module generates a trigger for a specific acquisition camera in order to start the capture process.

Image Acquisition: Starts frame capture when a train is detected. Frame rate adapts dynamically based on train speed. Frames are stored in the cloud and metadata is sent to Classification Module to start processing those images.

Processing: Classifies images and applies Deep Learning and OCR techniques to extract relevant features. For Can Tunis installation, those required features are:

- **European Vehicle Number (EVN):** number which identifies each vehicle of a composition, i.e. the locomotive and wagons.
- **Intermodal Loading Unit (ILU):** Code which identifies an intermodal container.
- **Intermodal Maritime Organization (IMO) placards:** which identifies Dangerous Goods carried by a wagon or container.
- **UN number:** Orange plate with a four-digit code which identifies hazardous materials carried by a wagon or container.

Integration: Aggregates processed data from different modules into a single unified output per train. Establish the interface with external systems, such as Traffic Management Systems (TMS) or Terminal Operating Systems (TOS) adapting the generated information to a Conceptual Data Model (CDM).

6.6 Test plan

The following is a description of the test plan for the installation and validation of the Railway Checkpoint systems at the Can Tunis rail terminal. The main objective is to ensure that the installed systems, including sensors, cameras, and analysis software, comply with the functional and operational requirements defined for a European Railway Checkpoint.

The plan includes various tests to validate the performance, accuracy and reliability of the system under operating conditions. The system's ability to monitor track occupancy, identify rolling stock and capture relevant data upon train arrival will also be evaluated.

The tests are structured around the following axes:

- Functional verification of installed components (detection, identification, analysis).
- Operational validation in representative rail traffic scenarios.
- Evaluation of system robustness and reliability.

This test plan defines the verification activities required to demonstrate that the Railway Checkpoint System meets its specified functional and operational requirements. The tests are designed in accordance with industry best practices for validation and verification, as outlined in IEC 61508 [8] and ISO 9001 [9] and shown in Figure 6.22, while considering that ERC system has no safety-related functionalities.

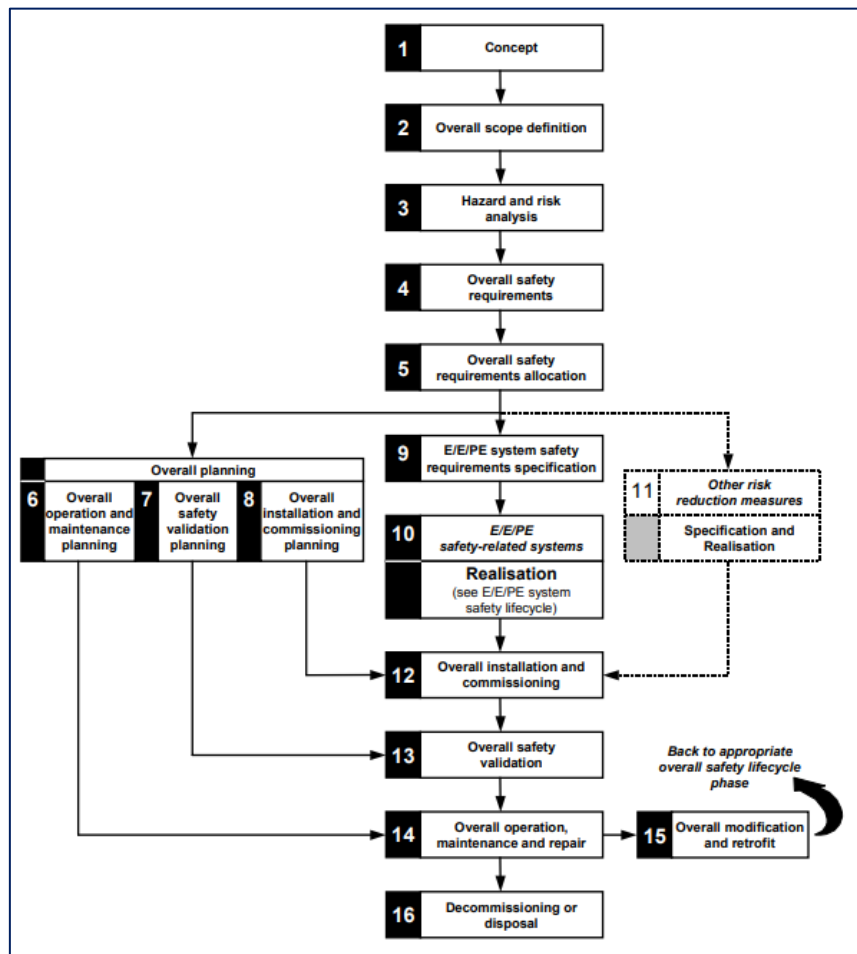

Figure 6.22 Global Safety lifecycle. Figure 2 of the standard IEC 61508

The goal of the validation process is to ensure correct performance of hardware, software, and data flows. Each test includes a defined procedure and expected result, enabling objective assessment of system behaviour and quality throughout its implementation lifecycle.

6.6.1 Hardware tests

HT-0001. Detection Cameras

Description: Verify that the detection cameras capture a clear and suitable image of all tracks on which the trains to be detected will run.

Procedure:

- Simulate rolling stock in the detection area.
- Observe the images, resolution, illumination and Field of View (FOV).

Expected results: The captured images allow software models to identify a train at a sufficient distance.

HT-0002. Presence Sensors

Description: Validate sensor alignment and detection reliability as ground truth mechanism.

Procedure:

- Simulate rolling stock passing the sensor line, at least 10 passes to verify detection consistency.
- Observe detection consistency across multiple passes.
- Test sensor alignment calibration (emit/receive pair).

Expected results: Sensors trigger accurately on train arrival/departure with zero false positives/negatives under proper alignment.

HT-0003. Acquisition Subsystem (Cameras and lights)

Description: Ensure acquisition cameras -IR and RGB- and lighting systems capture high-quality side and overhead images.

Procedure:

- Simulate the presence of a train at the desired distance.
- Trigger image capture multiple times.
- Inspect lighting synchronization and adaption. Light must be uniform across the entire image
- Inspect image resolution and focus.

Expected results: High-resolution images are captured in real-time, with sufficient lighting and contrast for later processing. The validity of the captured images shall be determined by their suitability for processing by the developed software models. The images shall meet the following requirements:

- The images shall remain in focus across the entire operational distance range at which trains may traverse, perpendicular to the camera axis.
- The images shall be free from pixel displacement and motion.
- There must be no objects occluding the field of view of the image.

HT-0004. Communications

Description: Verify stability and bandwidth of Ethernet and 4G/5G communication across EDGE/CLOUD modules.

Procedure:

- Simulate data flow from subsystems through network -images and metadata shared between modules-
- Monitor packet loss, latency, and throughput.

- Test failover between Ethernet and 4G/5G.

Expected results: Reliable, low-latency transmission of data and no data loss.

6.6.2 Functional tests

6.6.2.1 Subsystems

FT-0001. Train Detection

Description: Detect presence, speed, direction of approaching train.

Procedure:

- Simulate train approach with different speed ranges.
- Log detection data.

Expected results: Train detected correctly; speed and direction logged accurately.

- The system shall detect the train and report it within 4 seconds (maximum),

FT-0002. Acquisition rate

Description: Capture frames simulating a detection message.

Procedure:

- Simulate and send a detection message.
- Save captured frames and log acquisition data.
- Verify that acquisition rate matches the train speed. All captured images must cover the whole side of the train, avoiding any information not captured in the image.

Expected results: All frames and information registered matches the train speed, identified by train detection.

FT-0003. Classification process

Description: Feed frames to the classification process and verify that classification information is correctly generated.

Procedure:

- Feed Rolling Stock-captured frames to the classification process.
- Log classification results.
- Check that only the required classes (EVN, ILU, IMO, UN) are included in the output.

Expected results: Classification information matches the required classes (EVN, ILU, IMO, UN).

FT-0004. Processing process

Description: Feed frames and classification information to the processing process and verify that classification information is correctly generated.

Procedure:

- Feed Rolling Stock-captured frames to the processing process.
- Feed classification information – associated to each frame -.
- Log processing results and verify that format is correct – check information structure, attributes and verify that all classification classes generate a processing response.

Expected results: Processing information format matches the required one.

FT-0005. Data Fusion output.

Description: Feed processing results of one determined train to the data fusion process and verify the format of the resulting information.

Procedure:

- Feed processing results -traces- of one train to the data fusion process asynchronously.
- Log the data fusion output.
- Verify that the format of the output is correct

Expected results: Data Fusion information format matches the required one:

- There is only one train ID in the message.
- Wagons are correctly ordered.
- There is only one EVN per wagon or zero if no EVN was recognized.
- The number of recognizes ILU codes does not exceed the number of identified containers.
- Format and structure match the CDM specification for Train Composition.

6.6.2.2 Integration

IT-0001. Train Detection – Image Acquisition

Description: Ensure trigger from detection correctly initiates image capture.

Procedure: Simulate train detection and verify capture event.

Expected results: Camera starts image acquisition within ≤ 4 seconds upon detection.

IT-0002. Train Detection – Image Repository

Description: Ensure acquired images are correctly saved in the image repository.

Procedure: Start the acquisition procedure and save images in the repository.

Expected results: All images are correctly saved in the repository and no information is lost. The number of images stored in the repository must match the number of images captured by the system.

6.6.3 Operation tests

OT-0001. Wagon identification accuracy

Description: Verify the system's reliability in detecting and extracting the EVN from each wagon in the train composition.

Procedure:

- Capture images of trains crossing the ERC in operation (e.g. five trains).
- Count the number of wagons recorded. The number of wagons match the number of EVNs.
- Compare the extracted EVNs against a manually recorded ground truth.

Expected Results: The system must achieve an accuracy of at least 95% on the defined ground truth.

OT-0002. Dangerous Goods identification accuracy

Description: Evaluates the system's capability to detect and interpret hazardous materials indicators, such as IMO placards and UN numbers, from containers and wagons, ensuring compliance with safety regulations (RID [10], ADR/Directive 2008/68/EC, and UN Model Regulations).

Procedure:

- Feed frames of freight wagons/containers carrying dangerous goods into the process.
- Log results for IMO and UN classifications.
- Verify that the system only recognized valid classes (defined by UN and RID regulations).

Expected results: The system's outputs for IMO and UN recognitions only matches valid classes for IMO and UN. The system achieves at least a 93% accuracy on IMO and UN recognition.

OT-0003. Yard occupancy control

Assesses the system's performance in monitoring and updating the real-time status of rolling stock within the rail yard, enabling accurate tracking of which tracks are occupied and supporting efficient yard management.

7 On-board sensors

7.1 System Description

Thanks to the support of RENFE and ADIF, certain needs have been identified by the various stakeholders involved in freight transportation. The On-board system proposed by CEIT can cope with these issues. The features or functionalities that this On-board system can provide are related to logistics and operation, wagon monitoring, and cargo monitoring.

The aim of the On-board system is to digitalize the entire train and to obtain meaningful information for operation, maintenance, and logistics. As can be seen in Figure 7.1, the information gathered by the On-board system can be sent to the locomotive, to the checkpoint, or directly to the cloud. Therefore, this system can function autonomously within the train and provide valuable information to a platform accessible by different end users.

However, the On-board system lacks certain functionalities or capabilities that the checkpoint would cover, and vice versa. Since the checkpoint can only analyse the train when it passes through, and the On-board system continuously monitors the wagon regardless of its location, it would be useful to relate this data with the information generated by the checkpoint. The On-board system can provide complementary information that cameras might not capture, due to technological limitations.

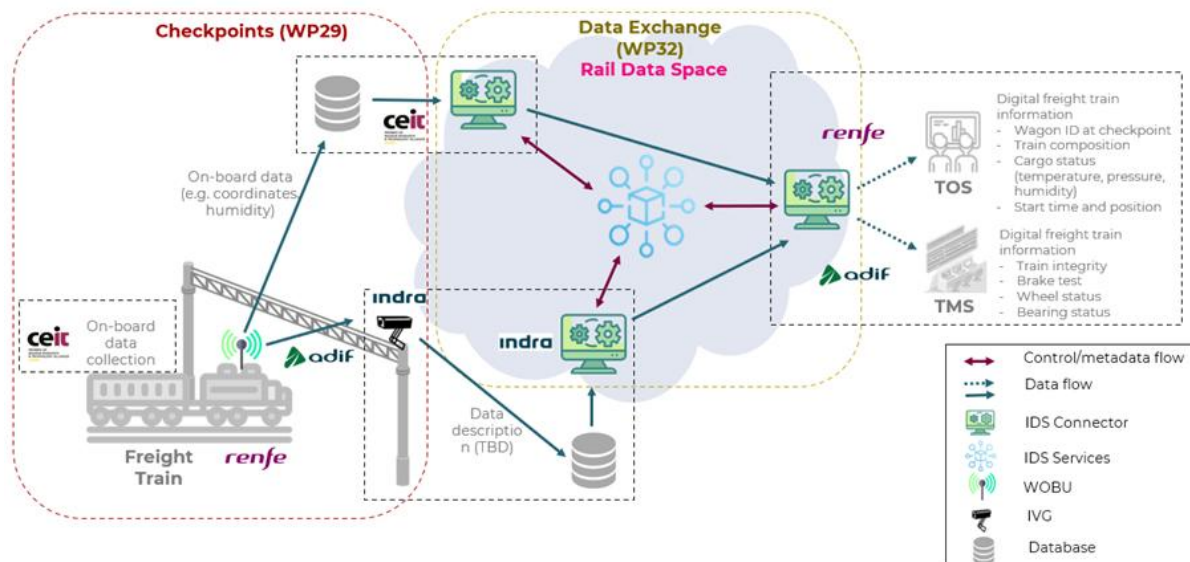

Figure 7.1 Demonstrator description for WP33

Focusing on the On-board system, as shown in Figure 7.2, this system can utilize various network topologies to address the diverse stakeholder requirements. Wireless Sensor Network (WSN) architecture is the most practical option for this type of application. Unlike

wired alternatives, it allows for economical installations in remote and challenging environments.

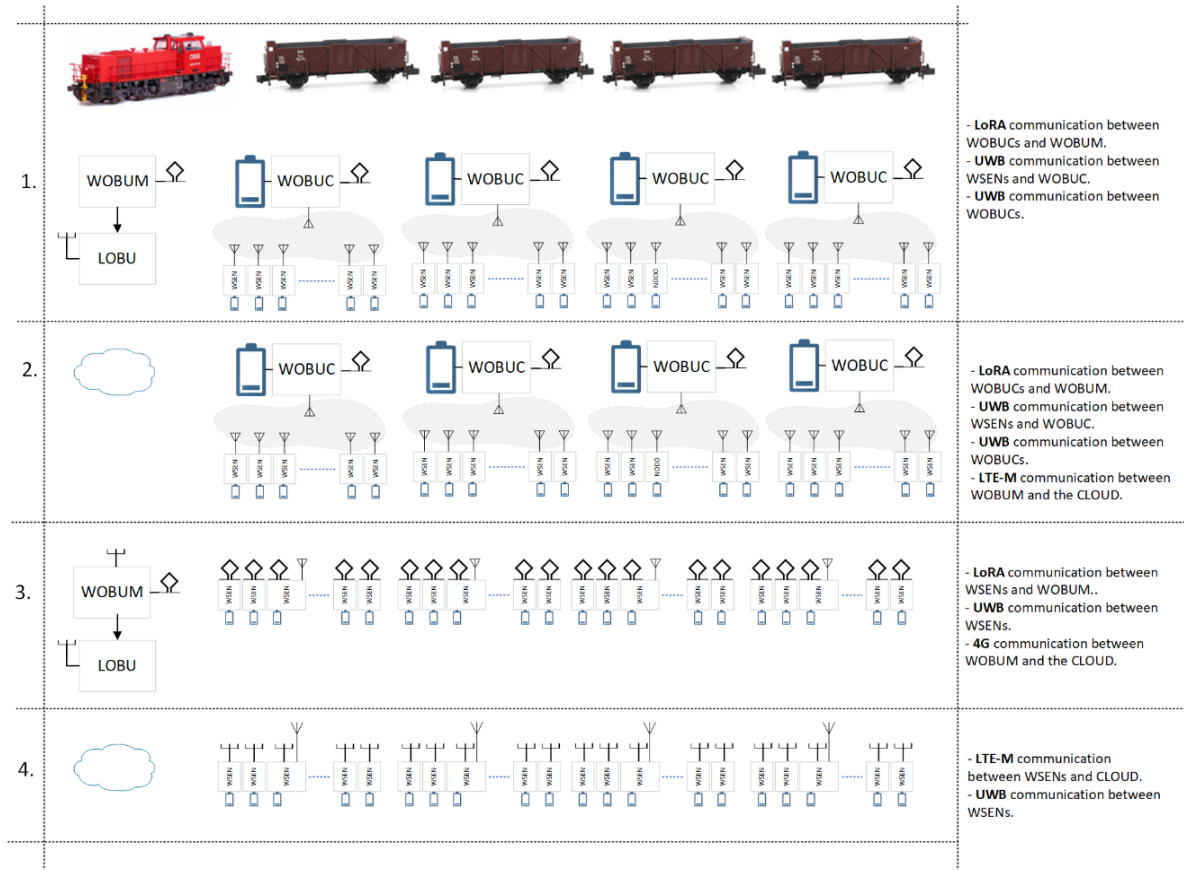

Figure 7.2 Network Topologies for the On-Board Digital System in Railway Logistics

The physical components within the On-board system are:

- **Wireless Sensor Node (WSEN):** These will be its main functionalities when they will be deployed in future activities:
 - Detection of Hot Axle.
 - Detection of Blocked Brakes.
 - Detection of flat wheel.
 - Automatic Brake Test.
 - Cargo monitoring.
- **Wireless On-Board Unit Coordinator (WOBUC):** These could be its main functionalities once the system will be fully deployed:
 - Manage the network of WSEN deployed in the wagons using Ultra-Wideband (UWB), a radio technology which enables high-precision location tracking and short-range data communication.
 - Geolocation using Global Navigation Satellite Systems (GNSS).
 - Train Composition.

- Train Integrity.
- Communicate with the Loco On-Board Unit (LOBU) using Long Range (LoRA) or, with the cloud via Long-Term Evolution for Machines (LTE-M), to be re-configured and/or transmit the information generated by the wagon elements (WOBUC or WSEN).
- **WOBU Master (WOBUM):** These are its main functionalities:
 - Manage the network of WOBUs using the LoRA link.
 - Redirect all the information generated in each wagon to the LOBU.
 - Redirect all requests generated in the LOBU to each WOBU.
- **LOBU (Loco On-Board Unit):** It is responsible for configuring the operating mode of each wagon, collecting the data sent by each WOBU, temporarily storing it, and sending it to a cloud database or tablet:
 - Data is sent to the cloud database using a communications modem (3G/4G).
 - Data is sent to the tablet via Wireless Fidelity (Wi-Fi).
- **Driver desk:** A graphical interface that allows the user to interact with the On-board system. It can be connected to either the LOBU or the cloud.

To enable the deployment of a flexible network topology, CEIT has developed a modular device (Figure 7.3) offering the versatility to operate as a WOBUM, WOBUC, or WSEN. Equipped with multi-sensory hardware, this device offers comprehensive low-cost and ultra-low-power wireless connectivity. It leverages a state-of-the-art microcontroller, ensuring both low power consumption and robust computational capabilities for demanding operations. Due to its versatile nature, this device enables the digitalization of diverse elements in various environments. Consequently, the system can be tailored to meet the unique requirements of any client, effectively adjusting to their specific needs.



Figure 7.3 CEIT's modular device for WOBUM, WOBUC, or WSEN operation

This device incorporates various types of integrated sensors, including acceleration sensors, Inertial Measurement Units (IMU) comprised of a gyroscope and accelerometer, a magnetometer, a pressure sensor, an exterior and interior temperature sensor, a humidity sensor, an optical sensor, a microphone, and a GNSS/GPS receiver, as further specified later in this document. Additionally, this device also integrates IR-UWB (Impulse Radio Ultra-Wideband) wireless communication technology compliant with the IEEE 802.15.4a standard, LoRa communication technology, Bluetooth Low Energy v5.3, and cellular technology with global LTE-M/NB-IoT coverage.

To track and locate goods in the logistics sector, this device offers geolocation capabilities, facilitating asset monitoring and accurate time synchronization. Moreover, leveraging its integrated technologies and advanced localization techniques, it can precisely estimate distances between adjacent devices down to the centimetre. Lastly, this device features a battery monitoring system that provides its current state. This crucial data facilitates the deployment of advanced power optimization and management strategies, thereby maximizing the battery's operational life.

7.2 System operation

As mentioned earlier, the device can operate as a WOBUM, WOBUC, or WSEN. Its operation and power consumption will vary depending on the role it assumes. If assigned the WSEN role, the device will be placed in a specific part of the wagon, based on the required functionality or the variables needing to be sensed. Depending on the implemented network topology, the WSEN can send data to a WOBUC, a LOBU, or directly to the cloud. If assigned the WOBUC role, the device will likely be positioned at an intermediate point to act as a coordinator for the sensor node network, redirecting information toward the LOBU or the cloud.

The sensor node operates in two modes: a low-power mode and an active mode. The sensor node sends out beacons periodically, awakened by its internal RTC (Real-Time Clock). This ensures it remains in an ultra-low-power state unless it needs to take measures, send information, or transmit a beacon via its wireless communications. In ultra-low-power mode, all system devices are off except for the microcontroller. In active mode, the system manages the powering on and off the necessary power sources for devices required to perform operations like measurements, data storage, or wireless communications.

This operation is illustrated in Figure 7.4. Each time a Sensing event (Tsens) occurs, the WSENs activate, acquire and process data, and then transmit the results via UWB to the WOBUC. Therefore, the WOBUC must be awake to receive data from all WSENs. Once a WSEN has finished transmitting, it returns to ultra-low-power mode. Similarly, when the WOBUC has received data from all WSENs, it forwards the data to a WOBUM via LoRa communication or to the cloud using LTE-M, and then also returns to ultra-low-power mode.

On the other hand, each time a communication event (T_{com}) occurs, the WOBUC establishes communication with either WOBUM or the cloud. This is done to receive commands for reconfiguring the WSENS or the WOBUC itself, or to carry out operations between different WOBUCs.

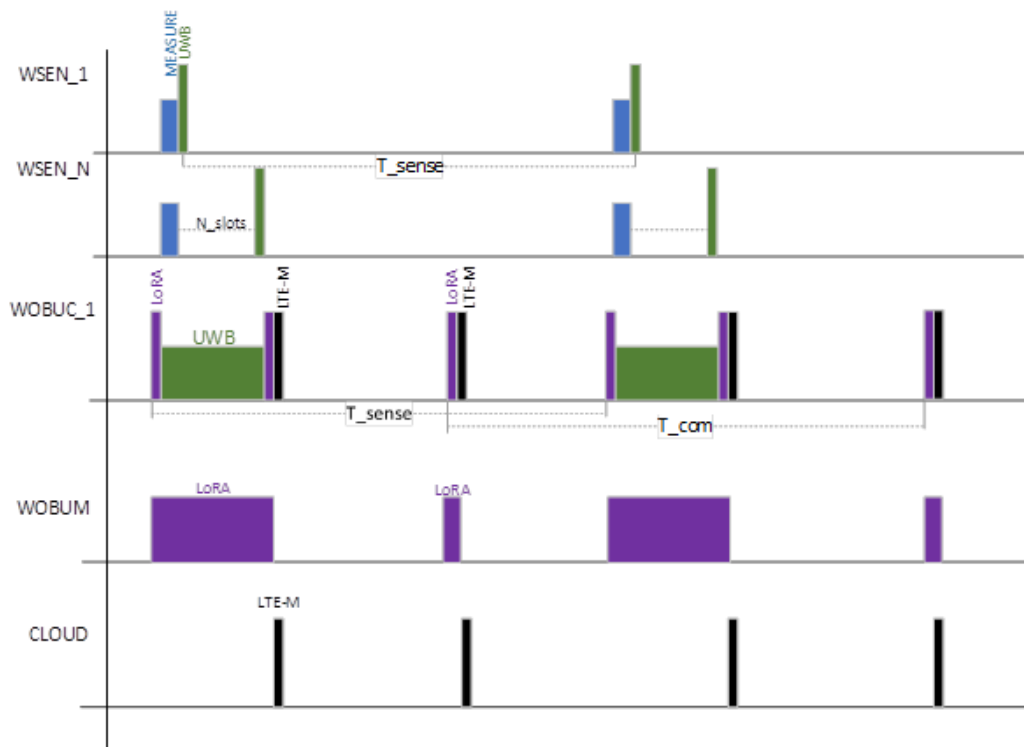

Figure 7.4 Device Operation According to its Role Within the System

It must be noted that WOBUCs transmit data to the cloud over LTE-M, leveraging the Message Queuing Telemetry Transport (MQTT) protocol. Each WOBUC publishes its collected data to designated broker topics. Furthermore, the device is subscribed to relevant topics to receive messages intended for it. It is perfect for this type of system because it requires few resources, consumes little power, and is well-suited for limited-bandwidth or unstable networks. It enables efficient bidirectional communication between devices and the cloud.

7.3 Functional features

The functions of the On-board system are to track the wagons, identify anomalies or failures during operation, and provide valuable logistical information. As previously stated in Deliverable D29.1, Table 7.1 shows a list of the operations the On-board system can perform, along with the parameters associated with each functionality. It can also be seen what type of alarm would occur and whether the data generated by the On-board system can be related to the data from the checkpoint (penultimate column). Note that each of these data will be associated with a timestamp so that it can be compared with the data from the checkpoint.

Table 7.1 List of parameters generated by the On-board system

			ALARM	Checkpoint	GCU code
Condition monitoring	Flat Wheel monitoring	Chord length. (mm) Height (mm)	Excessive flatness in a wheel	Yes	1.3.2 1.3.3
	Bearing monitoring	Temperature (°C). Maximum vibration frequency along XYZ axes (Hz). Amplitude (mG)	ID of the hot axle or brake blocked	Yes	1.8.3
	Spring monitoring	Maximum vibration frequency along XYZ axes (Hz). Amplitude (mG)	Spring ID failure	No	1.3.2 1.3.5
Operational & logistics	Automatic Brake test	Amplitude along XYZ axes, brake release 0 (mG). Amplitude along XYZ axes, brake applied (mG). Amplitude along XYZ axes, brake release 1 (mG).	Brake ID system failure	No	3.1.5 3.3.1 3.3.2 3.3.3
	Kingpin test	Lock/unlock	Coupling system failure	Yes	N/A
	Wagon Composition	WoBU ID and its position within the train	N/A	Yes	N/A
	Wagon Integrity	WoBU ID and its geolocation. Position within the train. WoBU ID in the front. Distance to the front (m). WoBU ID in the back. Distance to the back (m).	Integrity error on WOBU ID.	No	N/A
Cargo monitoring		Temperature (°C). Humidity (%).		No	
	Freight status	Pressure (hPa)	N/A		N/A

From an efficiency standpoint, there is no advantage in continuously sending raw data or parameters related to these operations. Therefore, the data must be meaningful and enable us to compare how the checkpoint and On-board systems interpret the results.

7.4 Use case

In the use case that CEIT is proposing with RENFE and ADIF, the aim is to compare the data generated by the On-board system with the data acquired by the checkpoint. Next, some functions that the On-board system from CEIT will perform are described in detail, along with how the alarms are generated.

7.4.1 Operational & Logistics

- **Train Composition**

This functionality is a pivotal aspect of freight train operations. Train composition refers to the strategic organization and assembly of wagons to form an efficient transport unit. In the realm of freight trains, the proper composition of the train holds paramount importance in terms of safety, efficiency, and operational profitability.

The significance of train composition lies in its ability to optimize various aspects of freight operations. By carefully arranging and identifying the wagons that comprise the train, logistics managers can ensure the optimal distribution of weight, efficient load balancing, and improved overall train performance. This facilitates effective resource allocation, load planning, and cargo management, leading to streamlined logistics processes and enhanced operational efficiency. Also, it has implications for rail infrastructure; an efficient cargo distribution strategy reduces the stress on the tracks and other infrastructure elements, minimizing wear and tear in the long run.

Moreover, train composition plays a crucial role in ensuring seamless connectivity between the wagons, enabling efficient coupling and decoupling operations. The ability

to accurately identify and track the wagons within the train formation is essential for efficient operations, as it facilitates real-time monitoring, identification of specific cargo, and efficient utilization of resources.

Objective:

- To automate the identification and verification of train composition, improving operational safety and efficiency.

Process:

- The Driver Desk, located on the locomotive or in the cloud, initiates a "discovery" request.
- Each wagon, equipped with a WOBUC (Wagon On-Board Unit Controller), responds to the request.
- The WOBUC transmits essential information, such as wagon identification, type, and its distance to nearby WOBUCs.
- This data is processed to determine the train's current composition and the position of each wagon.
- The system reports the composition to the Driver Desk or the cloud, validating the train's integrity.

Checkpoint Role:

- Verifies the train's composition as it passes, comparing the on-board system's information with each wagon.
- Acts as a control point to confirm that the train's composition has not changed.
- Cannot provide composition information during marshalling operations.

Status:

Under development. The on-board system and checkpoints work together to automatically provide and verify composition information, ensuring a smooth and safe operation.

- **Wagon Integrity & Geolocation**

After the train composition is finalized, the Driver Desk can command an Integrity & Geolocation process on each WOBUC. Each WOBUC then reports its geolocation and the distances to the adjacent WOBUCs (both forward and backward). This collected data is processed to track individual wagons and confirm the continued attachment of adjacent ones. Finally, this information, comprising the WOBUC ID and its processed data, is relayed to either the Driver Desk or the Cloud.

Information on a train's geolocation and composition is available from the checkpoint only as the train passes. Consequently, this functionality delivers beneficial intelligence to the checkpoint, streamlining operational logistics.

This function is nowadays managed by the signalling system of each track and country. The integration of this function in this On-board system follows the trend to economize systems for a more agile operation. Its reliability and use needs to be proved when the system will be fully deployed during this project and the second wave of FA5.

- **Automatic Brake Test**

The brake test involves verifying the functionality of each brake. The brakes are applied from the locomotive to confirm they engage correctly throughout the train. This involves observing if the brakes respond uniformly on each wagon. This operation is crucial in the preparation phase of the train, prior to the start, and it is often performed by walking the length of the train to visually inspect the brake cylinders. After applying the brakes, they are then released to ensure they disengage properly. Again, workers check each car and axle to verify that the brakes have been released as expected.

Objective:

- Verify the correct application and release of all brakes across the train automatically, eliminating the need for manual, visual inspection by workers. This test aims to avoid the worker from having to verify through visual inspection whether the brake has applied and released. The operation involves the driver applying and releasing the brake while the onboard system measures accelerations.

Process:

- The driver initiates the brake test from the locomotive.
- The driver applies and releases the brakes.
- Wagon sensors (WSEs) measure acceleration responses during the test.
- An embedded algorithm determines if each brake applies and releases correctly, confirming uniform response across the train.
- The final results are reported to the Driver Desk, indicating success or failure and specifying the exact location of any failing brake.

Checkpoint Role:

- The checkpoint cannot perform the brake test directly, as it may not be in the location required for the operation.
- It can verify that the test was conducted correctly by indirectly confirming that the brakes have been released (e.g., ensuring wheels are not blocked).

Status:

- Currently under development. Raw data from each WSEN is being collected and transmitted to the Driver Desk.

- The purpose is to enable future post-processing and analysis of this data in a laboratory setting, supporting the development and validation of the automatic brake test algorithm.

7.4.2 Condition monitoring

Condition-Based Maintenance (CBM) and Anomaly Detection are two key concepts enhancing freight train management, shifting from a reactive to a predictive and proactive approach. CBM and Anomaly Detection transform maintenance from a necessary expense into a smart strategy that enhances safety, optimizes costs, and maximizes efficiency in railway freight transport.

CBM is based on the continuous monitoring of a wagon's components and systems. Instead of performing maintenance according to a fixed schedule or after a failure occurs (corrective maintenance), CBM uses sensor data to determine when intervention is truly necessary.

Anomaly detection involves the identification of data patterns or points that substantially deviate from established normal or anticipated behaviour. Accordingly, if a sensor registers a parameter exceeding its defined thresholds or other data inconsistent with expectations, the system designates it as an anomaly. Such an anomaly may indicate the early onset of an imminent failure or a condition warranting intervention.

In the developed system presented by CEIT in previous sections, the WSEN device placement within the wagon would be determined by the specific functionality required or the variables slated for sensing. However, since the CBM and anomaly detection algorithms—for issues like excessive wheel flatness, hot axles, blocked brakes, or spring failure—are still under development, their definitive placement remains undetermined.

WSEN devices will be configured remotely from the Driver Desk to gather and send data according to a set schedule, as noted. Even though the on-board system is not currently capable of generating CBM or anomaly detection alarms, relevant data from each WSEN will be sent to the Driver Desk for later analysis. Moreover, the Driver Desk will be able to initiate a test to measure the accelerations from these WSENS over a defined time window.

7.4.3 Cargo monitoring

Cargo monitoring in the railway sector involves real-time tracking and data collection regarding the condition and location of goods transported within wagons or containers. This offers multiple key benefits for freight trains: it enhances cargo security by enabling immediate detection and action against anomalies like theft or damage; it increases real-time visibility and traceability for both operators and clients, leading to more precise logistics planning and supply chain optimization by anticipating and resolving bottlenecks

and delays. Additionally, it reduces losses and claims by identifying damage causes, facilitates regulatory compliance for sensitive goods, and ultimately improves the customer experience by providing detailed and updated information about their shipments.

In the developed system presented by CEIT in previous sections, in the same way as for condition monitoring, the WSEN devices will be configured remotely from the Driver Desk to gather and send data according to a set schedule. The parameters to be monitored will be the temperature, pressure, and humidity of the cargo.

7.5 Installation process

The enclosure of the On-board system devices developed by CEIT is a housing engineered to comply with the most stringent protection standards. It is constructed from a robust material that simultaneously allows for unobstructed wireless communications. For simplified system deployment, antennas are integrated within the casing. Lastly, to facilitate device installation, the housing will incorporate a tool-free neodymium magnet fastening method, eliminating the need for any additional tooling.

Figure 7.5 shows a diagram of the proposed deployment of the On-board system. Note that, for this use case, we will be able to equip up to four wagons, which amounts to one WOBUC per wagon.

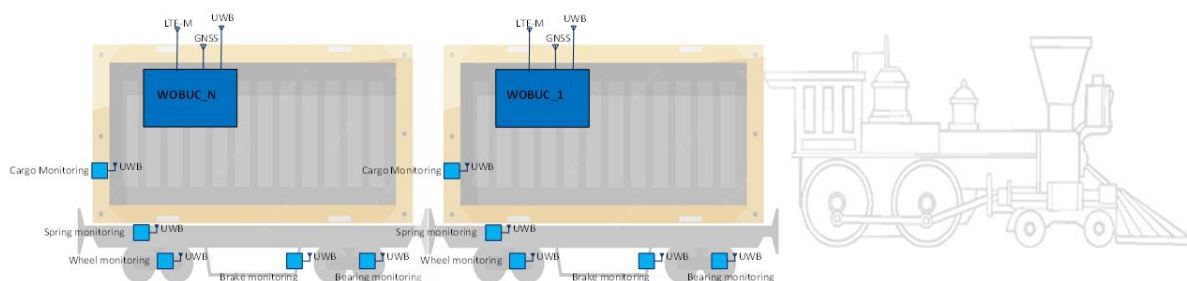

Figure 7.5 Deployment of the On-board system

We aim to install 1 WOBUC and up to 4 WSEN on each wagon. These sensors will measure parameters such as acceleration, angle, temperature, humidity, etc. The information gathered by the WSEN will be sent to the WOBUC within the wagon. The WOBUC will organize all this data and transmit it to the cloud.

The devices must be in the proper places so that they are able to work properly. Table 7.2 shows the placement of each device for the functions explained in sections 7.4.2 and 7.4.3.

Table 7.2 Placement of each On-board unit

		Unit	Placement	Image
Condition monitoring	Flat Wheel monitoring	WSEN1/2	Primary suspension (bogie frame and wheelset)	Figure 7.6
	Spring monitoring	WSEN1/2		
Operational & logistics	Automatic Brake test	WSEN3	On the brake beam of the brake linkage	Figure 7.7
	Wagon Composition	WOBUC	Central part of the bogie frame	Figure 7.8
	Wagon Integrity & Geolocation	WOBUC	Central part of the bogie frame	
Cargo monitoring	Freight status	WSEN	Closest to the cargo	

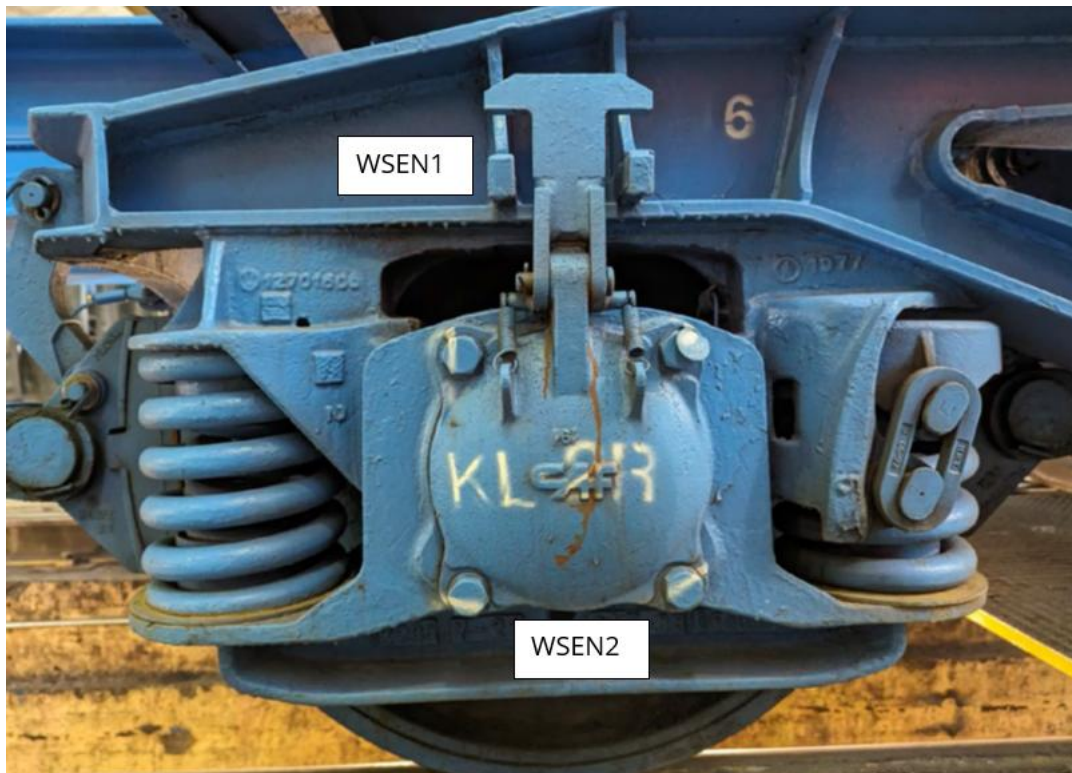

Figure 7.6 Primary suspension bogie frame and wheelset



Figure 7.7 Brake beam of the brake linkage



Figure 7.8 Central part of the bogie frame

7.6 Test plan

7.6.1 Technological tests

Description:

To verify the performance of the key on-board system components, including communication range, battery life, remote server dashboard integration, and remote action capability.

Procedure:

- **Communication Range:** The objective is to demonstrate the reliability of wireless data transmission throughout the entire length of the wagon, covering the maximum distance from one end to the other (usually less than 20 meters). The communication will be considered reliable if the received signal strength remains consistently above -100 dBm within this entire range.
- **Battery Life:** Monitor sensor operation duration under typical usage conditions, or measure the decrease in battery capacity over a given time.
- **Server Integration:** Test data exchange and compatibility with the cloud repository dashboard.
- **Remote Action:** Execute remote commands and confirm successful reception and implementation on board the train.

Expected Results:

- Data is transmitted reliably over the required operational distance.
- The battery lasts for the minimum specified operating time.
- The on-board system integrates seamlessly with the remote server's dashboard.
- The system can effectively receive and execute remote commands.

7.6.2 Functional test

In the following section, the test plan for validating the On-board functions will be presented. The test is described as well as the expected results. These tests are related to the functions described in section 7.4.

These functions primarily contribute to the reduction of operational dwell time at borders and other handover points. These will be measured by analysing data collected by the On-board system for the train composition and comparing operational times and efficiency before and after the system's implementation.

- **Automatic Train Composition:** The aim is to verify that GNSS, UWB, and the algorithm are working correctly. We expect to obtain the train's composition primarily in a static situation, that is, when the train is stopped. However, we will also attempt to perform this function while the train is in motion. Once the composition is obtained, the results will be stored in the cloud database so that we can cross-check them with those obtained by the IVG.
- **Integrity & Geolocation:** The aim is to verify that GNSS and LTE-M are working correctly. The command related to this function will be issued from the Driver Desk. We expect to obtain the train's geolocation during a time window the user defines via the Driver Desk.
- **Condition & Cargo monitoring:** Through these tests, we will assess the WSEN capacity to acquire sensor data, relay it to the WOBU via UWB, and upload it to the

cloud via LTE. The on-board system will be remotely configured from the Driver Desk to gather and send data according to a defined schedule.

7.7 Preliminary tests

First, it is worth noting that the on-board units have undergone vibration and shock tests in accordance with standard IEC 61373, as well as temperature and ingress protection (IP) tests.

CEIT has conducted initial tests on several wagons provided by RENFE at the Can Tunis terminal. Four WOBUCs were installed on four wagons and four WSENs on one wagon. The train moved several times between Can Tunis and Morrot, as shown on the map in Figure 7.9.



Figure 7.9 Test carried out between Can Tunis and Morrot

7.7.1 Installation issues

One of the main objectives of this first test was to identify any difficulties that may arise during installation, such as those related to mechanical installation, legislation or objections that wagon operators might raise, and wireless communication issues. The following sections describe each of these problems and the corrective actions implemented.

Mechanical Installation: Corrosion presents a significant challenge for freight wagons due to their constant exposure to weather, humidity, and, at times, chemical or saline

substances from transported cargo. This process progressively degrades metal surfaces, forming rust and other deteriorated layers. This surface degradation is precisely what makes it difficult to attach magnetized systems, as irregularities and non-ferromagnetic material (like rust) accumulating between the magnet and the metal surface drastically reduce the adhesion force. For a magnetic system to work effectively, it needs direct, clean contact with a ferromagnetic surface, something that corrosion severely compromises.

In these cases, to ensure proper adhesion of the On-board units, a metal plate had to be attached to the surface, as is shown in Figure 7.10.



Figure 7.10 On-board unit attached to the metal plate

Alternatively, when the intended mounting surface for the onboard unit was too small to ensure adequate securement, polished surface and cable ties (or fasteners) had to be used to guarantee stability.

Legislation or objections of wagon operators: We have been requested to draft a document for the modification of an onboard electronic system for RENFE wagons, adhering to regulations RUE 585 (requirements compilation) and RUE 402 (risk management)

A document has been proposed that outlines a general Information about the project, including its title, dates, location, and team. This is followed by a detailed description of the modification, presenting the new electronic system, its proposed location, and the rationale behind the change, along with identifying the affected wagons.

This document evaluates the effects of modification on operational safety, vehicle performance, maintenance (justified as minimal due to the temporary nature and non-operational status), Interoperability (not applicable due to non-interaction with coupling elements), and environmental impact (also not applicable). The document emphasizes the low complexity and negligible consequences, the magnetic installation is completely reversible, allowing it to be easily installed and removed without any permanent changes.

Detailed risk identification, evaluation (including probability and consequences), and mitigation measures are presented in a structured table format. The implementation process then outlines the plan, necessary resources, installation procedures, and required testing, including risk mitigation strategies.

Wireless communication: Observations indicate that 5G significantly impacts UWB communications, which are crucial for the communication between WOBUCs (as detailed in Section 7.1). Indoors, a range of approximately 20 meters has been attained. Nevertheless, in worst-case conditions—particularly when a 5G antenna is in close proximity to the WSN—the range only extends to 10 meters.

On the other hand, the train composition algorithm is very strict and requires very precise coordinates, distances, and orientation for each WOBUC. The coordinates appear to be quite reliable, although not always obtained; the UWB distances are not reliable as mentioned before, and the orientation provided by the magnetometer is also not reliable. To address these issues, we propose the following adjustments and/or modifications to meet the previously described functions:

Implement a two-WOBU-per-wagon setup, with one WOBU at the front and another at the back of each wagon. This ensures the distance between the front of one wagon and the back of the next is less than 10 meters, effectively preventing UWB communication problems.

7.7.2 Results Obtained

Train Composition: The wireless communication issues encountered hindered our ability to perform a robust and reliable train composition. Although the algorithm successfully detected and identified each WOBUC within the train (Figure 7.11), it was unable to assign a position number within the convoy.

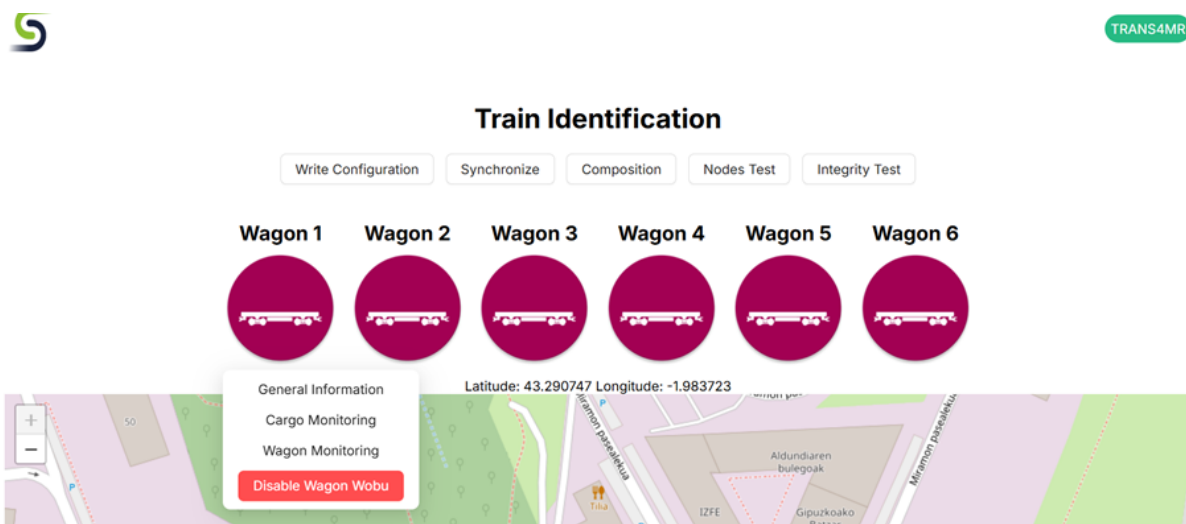

Figure 7.11 Dashboard: Convoy Wagon Details (Identification & Composition)

Integrity & Geolocation: From the Driver Desk, the request was sent, and the WOBUCs' positions were monitored on the dashboard map throughout the journey. This process served to validate the function's implementation, along with the robustness and reliability of LTE-M and GNSS communications. Figure 7.12 shows the driver's perspective along with the information provided by the Driver Desk.

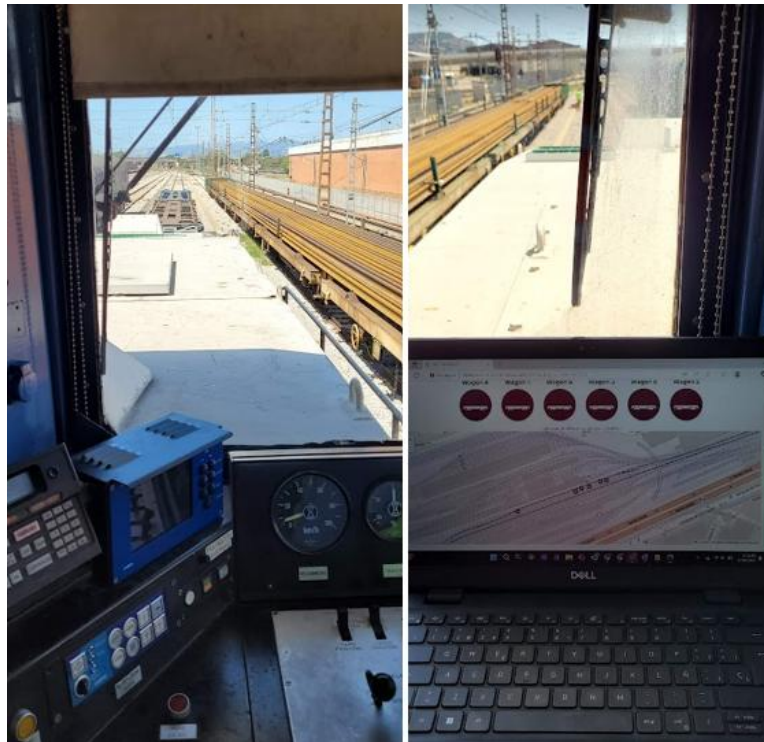

Figure 7.12 Driver view and the Driver Desk

Condition & Cargo monitoring: These tests confirmed the WSEN's capability to measure data, relay it to the WOBUC, and transmit it to the cloud database. From the Driver Desk as can be seen in Figure 7.13, Figure 7.14, and Figure 7.15, we reliably monitored the data captured during each TSENS event for the entire duration of the journey. Furthermore, the TSENS and TCOM periods were reconfigured mid-route, validating the system's robustness and reliability during the reconfiguration process.



Figure 7.13 WOBUC and WSEN units within the wagon

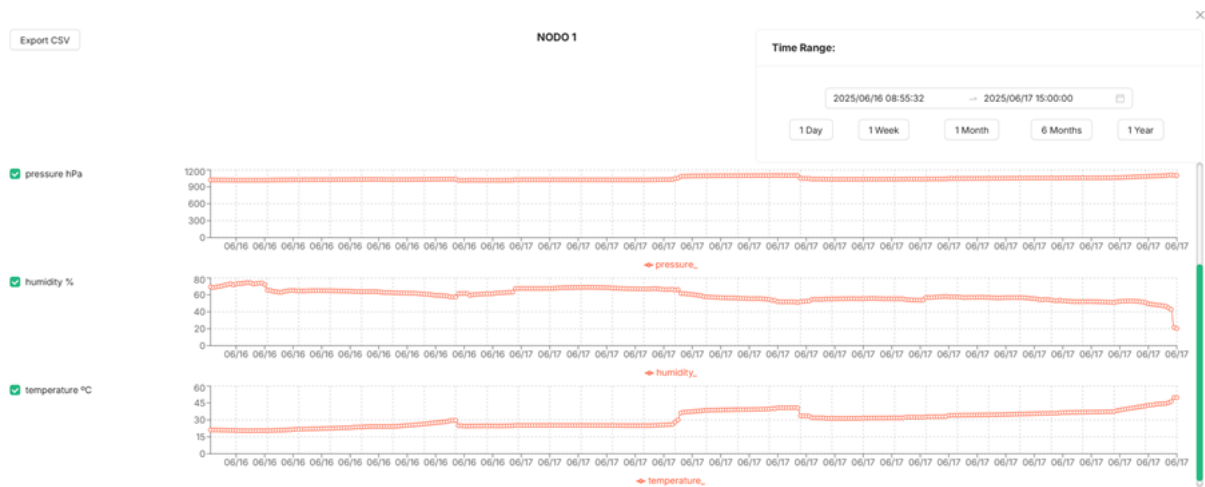

Figure 7.14 Parameters related to the Cargo Monitoring

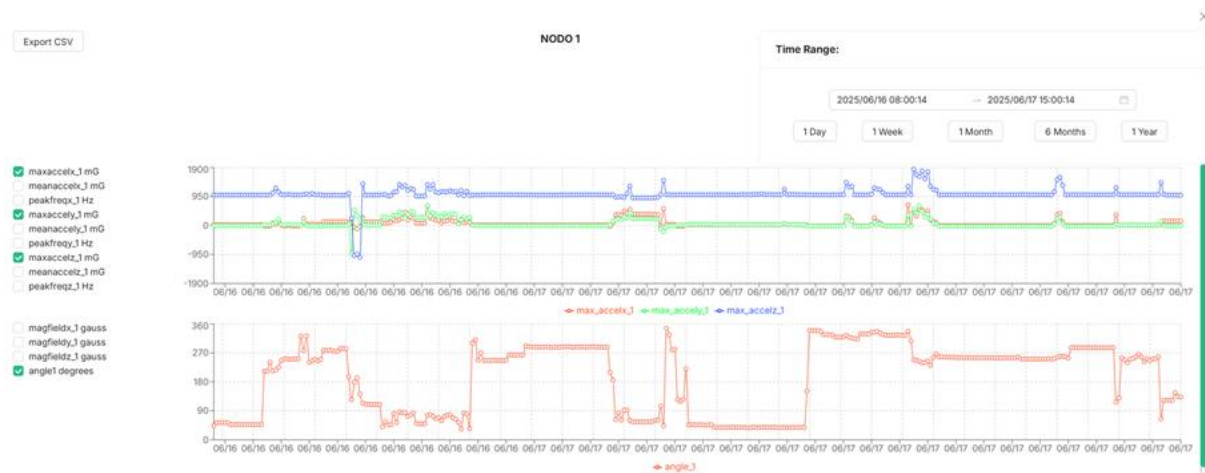

Figure 7.15 Parameters related to the Wagon Monitoring

Brake test: As pointed out in section 7.4.1, we are still working on the brake test algorithm. Therefore, data from different brake systems was recorded to aid in the development of the automatic brake test algorithm.

We asked the ADIFs locomotive driver to apply the brake several times. Simultaneously, a test was initiated from the Driver Desk to record accelerations from the four WSENS installed on the wagon's brakes. These measurements were taken at different sampling frequencies, ranging from 125 to 500 Hz, and within a defined time window. Figure 7.16 shows recorded accelerations measured by four WSENS along three axes for one of the brakes at a 250 Hz sampling frequency.

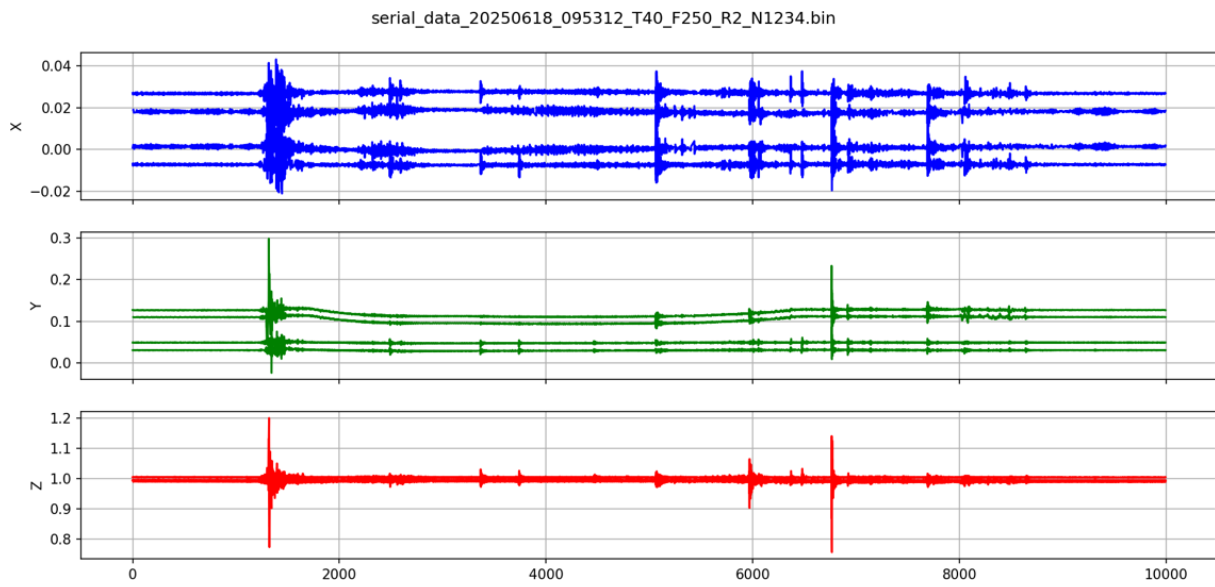

Figure 7.16 Brake test recording for 3-axis acceleration

8 Data sharing

To enable seamless and standardised data exchange between the European Railway Checkpoint (ERC) system and other railway information systems, data sharing must follow a structured, interoperable, and secure approach. The data exchange architecture adopted for the ERC demonstrator is aligned with the Conceptual Data Model (CDM) defined in Work Package 30 (WP30) of the MOTIONAL project (FP1), which aims to harmonise data semantics and structure across all flagship initiatives of Europe's Rail.

In this context, the ERC systems installed in Can Tunis shall share data with the TMS and TOS systems via a federated data-sharing framework. This exchange must comply with the CDM specifications concerning data entities (e.g., trains, vehicles, ILUs, irregularities), metadata (e.g., timestamp, geolocation, checkpoint ID), and data integrity attributes (e.g., confidence levels, version control).

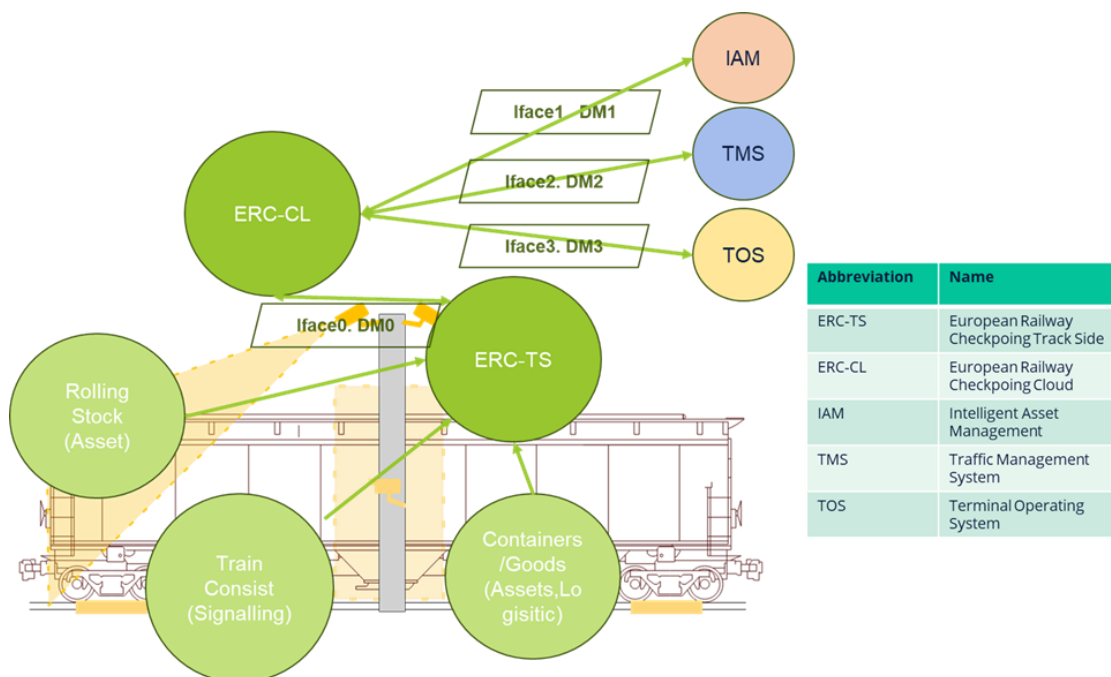

Figure 8.1 ERC data interfaces (reference to D29.1)

8.1 On-track data

The ERC system generates data through modular software processes (data fusion). Information published by the ERC correspond to the characterization of a certain composition containing the following information:

Geolocation of the checkpoint where the train is identified.

- Train ID: It identifies a specific train. Train ID might be operational -matched with the TMS or TOS- or synthetic -before matching the information.

- EVN: Vehicle identification, i.e. recognitions of the wagon's EVN. Each EVN must be ordered according to the composition. No more than 1 EVNs must be included for each wagon.
- Cargo (ILU): Identification of containers, associated to each EVN.
- Dangerous Goods (IMO and UN): Identification of dangerous goods tags, which can be associated to a wagon or a container.

Table 8.1 INDRA's composition message example (XML)

```

<train_description idvalue="00790">
  <train_id>00790</train_id>
  <irg_id>1001</irg_id>
  <track>1</track>
  <direction>-1</direction>
  <speed>40.0</speed>
  <total_length>0.0</total_length>
  <timestamp_init>2023-03-17 01:54:07</timestamp_init>
  <timestamp_end>2023-03-17 01:54:44</timestamp_end>
  <wagons_amount>10</wagons_amount>
  <wagons_description amount="4">
    <wagon id="0">
      <train_id>00790</train_id>
      <wagon_id>0</wagon_id>
      <EVN_code>None</EVN_code>
      <EVN_confidence>None</EVN_confidence>
      <image_name>None</image_name>
      <timestamp_init>2023-03-17 01:54:07</timestamp_init>
      <timestamp_end>2023-03-17 01:54:07</timestamp_end>
      <containers_amount>0</containers_amount>
      <containers_description amount="0" />
    </wagon>
    <wagon id="1">
      <train_id>00790</train_id>
      <wagon_id>1</wagon_id>
      <EVN_code>245114053001</EVN_code>
      <EVN_confidence>98.0</EVN_confidence>
      <image_name>None</image_name>
      <timestamp_init>2023-03-17 01:54:07</timestamp_init>
      <timestamp_end>2023-03-17 01:54:07</timestamp_end>
      <containers_amount>1</containers_amount>
      <containers_description amount="1">
        <container id="1">
          <train_id>00790</train_id>
          <wagon_id>1</wagon_id>
          <container_id>1</container_id>
          <isoilu_code>0</isoilu_code>
          <isoilu_confidence>0.0</isoilu_confidence>
          <un_code>0</un_code>
          <un_confidence>0.0</un_confidence>
          <container_classification>class5</container_classification>
          <container_classification_id>None</container_classification_id>
          <un_coordinates>0</un_coordinates>
          <imo_signs_amount>0</imo_signs_amount>
          <imo_signs_description amount="0" />
        </container>
      </containers_description>
    </wagon>
  </wagons_description>
</train_description>

```

```

</containers_description>
</wagon>
<wagon id="2">
  <train_id>00790</train_id>
  <wagon_id>2</wagon_id>
  <EVN_code>245114053002</EVN_code>
  <EVN_confidence>99.0</EVN_confidence>
  <image_name>None</image_name>
  <timestamp_init>2023-03-17 01:54:07</timestamp_init>
  <timestamp_end>2023-03-17 01:54:07</timestamp_end>
  <containers_amount>1</containers_amount>
  <containers_description amount="1">
    <container id="1">
      <train_id>00790</train_id>
      <wagon_id>2</wagon_id>
      <container_id>1</container_id>
      <isoilu_code>0</isoilu_code>
      <isoilu_confidence>0.0</isoilu_confidence>
      <un_code>0</un_code>
      <un_confidence>0.0</un_confidence>
      <container_classification>class5</container_classification>
      <container_classification_id>None</container_classification_id>
      <un_coordinates>0</un_coordinates>
      <imo_signs_amount>0</imo_signs_amount>
      <imo_signs_description amount="0" />
    </container>
  </containers_description>
</wagon>
<wagon id="3">
  <train_id>00790</train_id>
  <wagon_id>3</wagon_id>
  <EVN_code>245218057810</EVN_code>
  <EVN_confidence>98.0</EVN_confidence>
  <image_name>None</image_name>
  <timestamp_init>2023-03-17 01:54:07</timestamp_init>
  <timestamp_end>2023-03-17 01:54:07</timestamp_end>
  <containers_amount>1</containers_amount>
  <containers_description amount="1">
    <container id="1">
      <train_id>00790</train_id>
      <wagon_id>3</wagon_id>
      <container_id>1</container_id>
      <isoilu_code>UWPT1517611</isoilu_code>
      <isoilu_confidence>53.0</isoilu_confidence>
      <un_code>0</un_code>
      <un_confidence>0.0</un_confidence>
      <container_classification>class5</container_classification>
      <container_classification_id>None</container_classification_id>
      <un_coordinates>0</un_coordinates>
      <imo_signs_amount>0</imo_signs_amount>
      <imo_signs_description amount="0" />
    </container>
  </containers_description>
</wagon>
</wagons_description>
</train_description>

```

These messages, once validated, must be published using a data space connector, ensuring secure and monitored distribution across stakeholders. Each participating entity (e.g., ADIF, INDRA, CEIT) registers in the data space and implements middleware components to expose or consume datasets, negotiate contracts, and manage authentication and authorisation.

To ensure semantic consistency, the shared data must:

- Be structured according to the CDM (defined in D29.1 [1] and D32.2 [11]) entities and attributes (e.g., Train ID, Vehicle Number, UN Numbers, Gross Weight, Irregularity Codes).
- Include mandatory metadata such as timestamp, checkpoint ID, latitude, and longitude.
- Be transmitted using standard protocols (e.g. MQTT, RESTful APIs) over secure channels (e.g. HTTPS, VPN).
- Be serialised using machine-readable formats (e.g. JSON-LD or XML) compliant with the CDM.
- Be logged and traceable for auditing and validation through automated dashboards.

By adhering to these principles, the ERC system will facilitate the integration of checkpoint functionalities with rail freight operations, improving interoperability of the system.

8.2 On-board data

The following illustrates the data generated by the On-board system and its storage in the database. This data relates to the functions explained in sections 7.4.2 and 7.4.3.

Train composition: Table 8.2 shows the data that is generated by the On-board system and related to the Train Composition.

Table 8.2 Train composition data

	id [PK] integer	composition_index integer	composition_status text	index integer	lastupdated timestamp without time zone	status boolean
1	170	1	never	1	2025-07-02 16:39:33.43324	true
2	171	2	never	2	2025-07-01 11:42:47.426907	true
3	172	3	never	3	2025-07-01 11:42:57.989077	true
4	173	4	never	4	2025-07-01 11:42:44.300278	true
5	174	5	never	5	2025-07-01 11:42:54.240043	true
6	175	6	never	6	2025-07-01 11:42:43.60359	true

- **ID:** This is the physical id of the WOBUC associated with the wagon.
- **Composition Index:** The index of the wagon in the current train composition.

- **Composition Status:** This field is for knowing the composition status of the WOBUC, at this moment has three different inputs:
 - Never: The WOBUC is not in composition mode or has never been composed.
 - Waiting resp: The system is waiting for the device response to start the composition.
 - Resp: The reply from the device has been received and the WOBUC is already or is going to start composing in a few seconds.
- **Index:** This field is used to assign static indexes to physical IDs.

Wagon Integrity & Geolocation: Table 8.3 shows the data that is generated by the On-board system and related to the device's battery status and the geolocation.

Table 8.3 Integrity & geolocation data

	id_message [PK] integer	wobu_phy_id integer	wobu_net_id integer	wobu_time_stamp timestamp without time zone	latitude double precision	longitude double precision	altitude double precision	wobu_soc integer	wobu_capacity integer
1	8921	170	0	2025-05-30 14:48:47	43.278999999999996	-1.95	10.025	1	2505

Cargo monitoring: Table 8.4 shows the data that is generated by the On-board system and related to cargo monitoring, such as temperature, humidity and pressure.

Table 8.4 Cargo Monitoring data

	id_message [PK] integer	pressure_1 real	humidity_1 real	temperature_1 real	voltage_1 integer	capacity_1 integer	uwb_rx_1 integer
1	8927	1016.5	63.3125	25.5625	80	1928	-78

Wagon monitoring: Table 8.5 shows the data that is generated by the On-board system and related to Wagon Monitoring, such vibrations and temperature.

Table 8.5 Wagon monitoring table

	id_message [PK] integer	max_accelx_1 integer	mean_accelx_1 integer	peak_freq_1 real	max_accely_1 integer	mean_accely_1 integer	peak_freq_1 real	mag_fieldx_1 real	mag_fieidy_1 real	mag_fieidz_1 real	angle_1 real	temperature_1 real
1	8928	34	32	35.15625	-6	-6	35.15625	129	988	4.5	104.6875	25.546875

9 Conclusions

This document has presented a comprehensive overview of the Spanish demonstrator developed under Task 29.2, including the system architecture, installation procedures, and testing plans for both the Railway Checkpoints and the on-board sensor system. The integration of these two complementary technologies represents a significant step forward in the automation and digitalisation of freight train operations.

The planned installation of the Railway Checkpoints at the Can Tunis terminal, covering both the Llobregat and Morrot areas, have been carefully designed to ensure comprehensive coverage of key freight flows, enabling real-time data acquisition and improved traceability of wagon movements. However, the IVGs installation has not yet been completed due to the pending approval of the third-party impact document, which is required to proceed with the physical deployment. Despite this, the full installation and testing plans are already defined and documented in detail in this deliverable.

In contrast, the On-board sensor system has already been successfully installed and tested. Initial results confirm its potential to enhance data availability for monitoring and analysis of railway operations. Based on the tests performed, the TRL achieved is considered to be equal to the expected level. In summary, this is a functional prototype of the complete system, not merely a concept or a laboratory model. The tests were conducted under conditions identical to the end-use environment, validating that the technology, as a whole, performs as designed within its intended application. Nevertheless, further testing and refinement are still required to optimise system performance and ensure full integration with the overall demonstrator.

The testing plans outlined in this document are essential to validate the correct functioning of the demonstrator and will serve as the foundation for the upcoming deliverable *D29.6: Execution of Tests for Gates Installed in Spain*. By the time of that deliverable, it is expected that the Railway Checkpoints will be fully installed, allowing the execution of the planned test procedures. Additionally, further testing and refinement of the on-board sensor system will be carried out to improve its performance and ensure optimal data quality during future trials.

10 References

- [1] Kordnejad, B. (KTH) et al., "D29.1 Technical Definition of the Standard IVG for Checkpoints and Related Demonstrators," FP5-TRANS4M-R Project, 2024.
- [2] Kordnejad, B. (KTH) et al., "D25.1 Report on the basic functional and technical specifications for the realisation of the technical enablers of Seamless Freight, also including the final specification input for FP1," FP5-TRANS4M-R Project, 2024.
- [3] GCU APPENDIX 11, Inscriptions and Signs on Wagons, 2009.
- [4] United Nations Economic Commission for Europe (UNECE), UN Recommendations on the Transport of Dangerous Goods – Model Regulations, 21st Revised ed., 2021.
- [5] International Maritime Organization (IMO), International Maritime Dangerous Goods (IMDG) Code, 2020.
- [6] INDRA, "Separata de Afecciones Ferroviarias: Instalación de Pórticos Ferroviarios en Can Tunis," 2025.
- [7] Administrador de infraestructuras (ADIF), "NAE 107 Definición y medida de parámetros de la línea aérea de contacto (Catenaria)," 2022.
- [8] International Electrotechnical Commission (IEC), "IEC 61508:2010 – Functional Safety of Electrical/Electronic/Programmable Electronic Safety-Related Systems," IEC (Edition 2.0, Parts 1 to 7), 2010.
- [9] International Organization for Standardization (ISO), "ISO 9001:2015 – Quality Management Systems – Requirements," ISO (5th Edition), 2015.
- [10] RID, Regulations concerning the International Carriage of Dangerous Goods by Rail, 2025.
- [11] Gosavi, S (LSP) et al., "D32.2 Recommendations to reduce technical barriers and improve the quality and availability of data," FP5-TRANS4M-R Project.
- [12] Kordnejad, B., Åkerfeldt, M., Aronsson, M., Barbi, C. E., Diotallevi, C., Gotelli, G., Garcés Mencía, H., Irala Briones, A., Ivansson, G., Karl, J., Kjellin, M., Merle Carrera, L., Lengu, R., Posseger, E., Treiber, A., "D4.1 Description of functional and technical requirements and selection of components," WP4: Intelligent Video Gate, FR8HUB, Shift2Rail, 2018.
- [13] Kordnejad, B., Åkerfeldt, M., Aronsson, M., Barbi, C. E., Diotallevi, C., Garcés Mencía, H., Gotelli, G., Irala Briones, A., Ivansson, G., Karl, J., Kjellin, M., Lengu, R., Merle

- Carrera, L., Mitrovic, B., Nordmark, I., "D4.2 Technical Proof of Concept and Roll-out and Implementation Plan," WP4: Intelligent Video Gate, FR8HUB, Shift2Rail, 2019.
- [14] Kordnejad, B., Åkerfeldt, M., Aronsson, M., Gotelli, G., Irala Briones, A., Ivansson, G., Kjellin, M., Lengu, R., Merle Carrera, L., Müllerschön, J., Naranjo, A., Nordmark, I., Römer, H., Wießner, S., Wohlrath, R., "Deliverable D 3.1, Requirements definition and IVG preliminary installation report," WP3: Intelligent Video Gate, FR8RAIL III, Shift2Rail, 2020.
- [15] Kordnejad, B., Åkerfeldt, M., Aronsson, M., Irala Briones, A., Ivansson, G., Kjellin, M., Lengu, R., Merle Carrera, L., Nordmark, I., Olsson, E., Wohlrath, R., "Deliverable D 3.2, Description of demonstrator – Intelligent Video Gate," WP3: Intelligent Video Gate, FR8RAIL III, Shift2Rail, 2021.
- [16] Kordnejad, B., Åkerfeldt, M., Aronsson, M., Ivansson, G., Kjellin, M., Lengu, R., Nordmark, I., Rius García, G., Salvitti, G., Vilabella, S., Wohlrath, R., "Deliverable D 3.3, Demonstration and Evaluation including Best Usage of the Data Capture," WP3: Intelligent Video Gate, FR8RAIL III, Shift2Rail, 2022.
- [17] Gobierno de España, "Real Decreto 1434/2010, de 5 de noviembre, sobre interoperabilidad del sistema ferroviario de la Red Ferroviaria de interés general," Boletín Oficial del Estado.
- [18] Asociación Española de Normalización (UNE), "UNE-EN 50121-1:2017".
- [19] Administrador de infraestructuras (ADIF), "NAG 5-1-0.0 GÁLIBOS AUTOPISTA FERROVIARIA," 2024. [Online]. Available: https://www.adif.es/documents/20124/35737416/NAG5100_ED2_FC1.pdf/f4e3308a-7f5f-adc3-1eae-331d23883d9b?t=1729857363295.
- [20] European Union, Directive 2008/68/EC on the Inland Transport of Dangerous Goods, 2008.